

SERVICE INSTRUCTIONS

“PVWJ” B-FRAME PUMPS -025/-034/-046

FOR TYPE “P-1NN” AND “P-LNN”

PRESSURE COMPENSATING CONTROLS

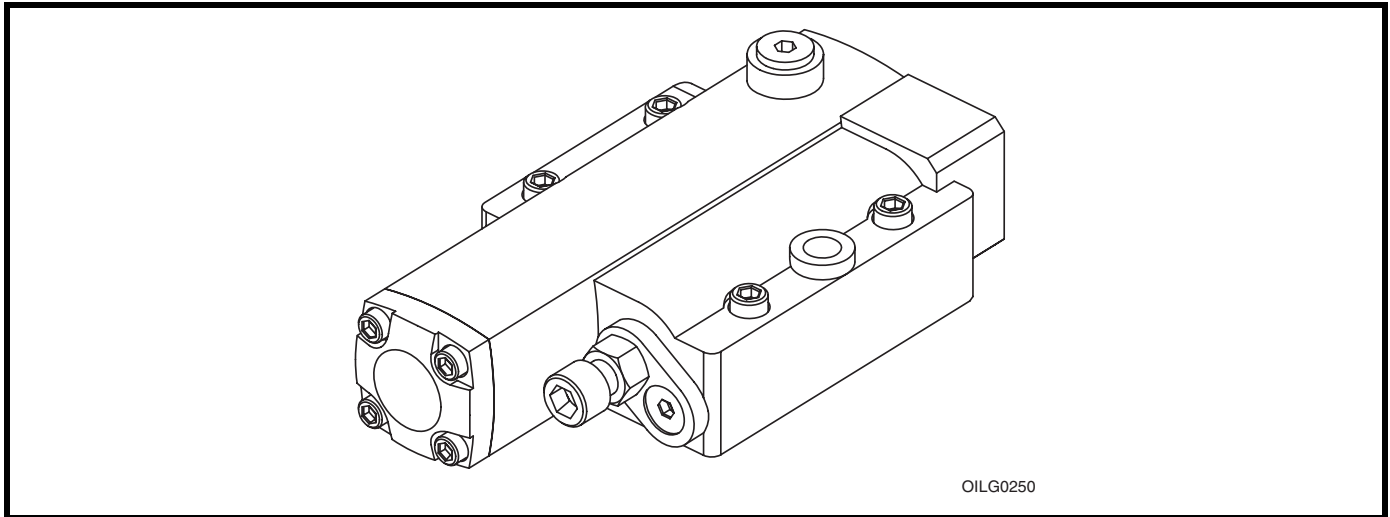

Figure 1. Typical Oilgear Type “P-1NN” and “P-LNN” Pressure Compensator Controls for “PVWJ” B-Frame Pump

PURPOSE OF INSTRUCTIONS

These instructions will simplify the installation, operation and maintenance of Oilgear type “P-1NN” and “P-LNN” controlled units.

This material will inform you about the basic construction, principle of operation and service parts listings. Some controls may be modified for specific applications from those described in this bulletin and other changes may be made without notice.

REFERENCE MATERIAL

Fluid Recommendations	Bulletin 90000
Contamination Evaluation Guide	Bulletin 90004
Filtration Recommendations	Bulletin 90007
Piping Information	Bulletin 90011
Proper Installation of Vertical Pumps	Bulletin 90014
PVWJ Open Loop Pumps, Application Guidelines	Bulletin 847085
PVWJ Open Loop Pumps (All Frame Sizes) Service Instructions	Bulletin 947085
PVWJ Open Loop Pumps, Sales	Bulletin 47085

PVWJ PUMP INSTALLATIONS

PVWJ B Frame (PVWJ-025/-034/-046) w/ Rear Ports.....	DS-47483
PVWJ B Frame (PVWJ-025/-034/-046) w/ Side Ports	DS-47484
PVWJ B Frame (PVWJ-025/-034/-046) w/ Side Ports & Thru Shaft.....	DS-47485

PVWJ PUMP CONTROL INSTALLATIONS

“P-1NN” and “P-LNN” Pressure Compensator for PVWJ-025/-034/-046	DS-47985
---	----------

THE OILGEAR COMPANY
 2300 South 51st Street
 Milwaukee, Wisconsin 53219
 www.oilgear.com

Safety First

Read and understand this entire instruction sheet before repairing, or adjusting your Oilgear product.

Those who use and maintain this equipment must be thoroughly trained and familiar with the product. If incorrectly used or maintained, this product and its equipment can cause severe injury.

SAFETY SYMBOLS

The following signal words are used in this instruction sheet to identify areas of concern where your safety may be involved. Carefully read the text and observe any instructions provided to ensure your safety.

DANGER

THIS SIGNAL WORD INDICATES AN IMMEDIATELY HAZARDOUS SITUATION WHICH, IF NOT AVOIDED, WILL RESULT IN DEATH OR SERIOUS INJURY.

WARNING

This signal word indicates a potentially hazardous situation which, if not avoided, could result in death or serious injury.

CAUTION

This signal word indicates that a potentially hazardous situation exists which, if not avoided, may result in damage to equipment or minor personal injury.

NOTE

While not directly relevant to the topic being discussed, the NOTE is used to emphasize information provided, or provide additional information which may be of benefit.

WARNING

This service information is designed for the maintenance of your Oilgear product. It contains the information on the correct procedures determined by Oilgear for the safe manner of servicing. Always keep this instruction sheet in a location where it is readily available for the persons who use and maintain the product. Additional copies of this instruction sheet are available through the Oilgear Company. Contact us at 414-327-1700 or visit our website: www.oilgear.com. Please contact us if you have any questions regarding the information in this instruction bulletin.

NOTE

The cleanliness of working on this pump control or the hydraulic system is extremely important to the safety and reliability of the pump and the system. Always make sure the fittings are clean on the outside before removing them from their connections, are capped and plugged when removed and placed in a clean rag or container until they are reinstalled.

WARNING

Some service operations may require special tools or equipment. If you require information on these items, please contact Oilgear before attempting these repairs and service operations.

WARNING

Read, understand and follow the safety guidelines, dangers and warnings contained in this instruction sheet to promote reliable operation and prevent serious personal injury.

WARNING

DO NOT attempt to service this machinery in an environment where safety regulations are not established and in place.

WARNING

DO NOT operate the hydraulic system if a leak is present. Serious injury may result.

WARNING

Hydraulic systems operate under very high pressure. Hydraulic fluid escaping from a pressurized system can penetrate unprotected body tissue. DO NOT inspect for hydraulic leaks with bare hands or other exposed body parts. As a minimum, wear leather gloves prior to inspecting for leaks and use cardboard or wood. If leaks are present, relieve pressure and allow system to cool prior to servicing. If injured by escaping hydraulic oil, contact a physician immediately. Serious complications may arise if not treated immediately. If you have questions regarding inspecting for hydraulic leaks, please contact Oilgear prior to servicing.

⚠ WARNING

Hydraulic hoses and tubing must be inspected on a daily basis for leaks, cuts, abrasions, damage and improper clearance along any mounting frame for hidden damage before the unit is put into service. Replace damaged hoses or hoses you suspect are damaged before the system is returned to service! Hoses must be replaced every two years. Failure to properly inspect and maintain the system may result in serious injury.

⚠ WARNING

Hydraulic systems are hot. **DO NOT TOUCH!** Serious personal injury may result from hot oil. When you have completed working on the hydraulic system, thoroughly clean any spilled oil from the equipment. Do not spill any hydraulic fluids on the ground. Clean any hydraulic fluids from your skin as soon as you have completed maintenance and repairs. Dispose of used oil and system filters as required by law.

⚠ WARNING

Use correct hoses, fittings, and adapters with the correct SAE rating when replacing hoses to prevent possible serious injury. Always replace hoses, fittings and adapters with replacements that have a proper, suitable, working pressure rating. Replacement hoses must be of the correct length and must comply with the hose manufacturer's and Oilgear's installation guidelines and recommendations.

⚠ WARNING

Hydraulic hoses have the SAE ratings marked on the hose to assist you in selecting the correct hose. The same manufacturer must supply any replacement hydraulic hoses and fitting assemblies. As an example: Brand "X" hose and brand "Y" fitting will not normally be compatible. No "Twist" is allowed in the hydraulic hoses. "Twist" may result in premature hose failure. This can cause serious injury. Please contact Oilgear for assistance when required.

⚠ WARNING

Hydraulic cylinders can be holding a function in a certain position when the pump is OFF. An example of this is a function being held in the lift or partial lift position by the cylinders. If a hydraulic line is removed or the hydraulic circuits or controls are being worked on, gravity may allow the function being held in position to drop. All workers and personnel must remain clear of these areas when working on or operating the hydraulic system. Block and secure all devices and functions which apply before beginning work or operation. Failure to comply with this can result in serious injury or death.

⚠ WARNING

Any hydraulic pipe which is replaced must conform to SAE J1065 specifications. If incorrect hydraulic pipe is installed, the hydraulic system may fail, causing serious injury. Damaged or leaking fittings, pipes or hoses must be replaced before the system is returned to service.

⚠ WARNING

DO NOT heat hydraulic pipe. The carbon content of this steel tube is such that if heated for bending, and either water or air quenched, the pipe may lose its ductility and thereby be subject to failure under high pressure conditions. Serious injury can result. Damaged or leaking pipes must be replaced before the system is returned to service. Please contact Oilgear if you require assistance or have questions.

⚠ WARNING

All hydraulic pressure must be relieved from the hydraulic system prior to removing any components from the system. To relieve the hydraulic pressure from the hydraulic system, turn off the motor and operate the control panel with the key in the ON position. Failure to comply can result in serious injury. If you have any questions concerning relieving the hydraulic pressure from the system, please contact Oilgear.

WARNING

Hydraulic components can be heavy. Use caution while lifting these components. Serious personal injury can be avoided with proper handling of the components.

WARNING

Please contact Oilgear if you require assistance. When performing hydraulic test procedures, use the proper hydraulic gauges. Installing an incorrect test gauge could result in serious injury if the gauge fails. Use properly rated hydraulic hoses to allow the test gauge to be read away from moving parts and functions.

WARNING

Increasing hydraulic pressure beyond the recommendations may result in serious damage to the pump and system or serious personal injury and may void the Oilgear Warranty. If you have questions concerning hydraulic pressures or testing procedures, please contact Oilgear before attempting the test procedures or making adjustments.

WARNING

An Oilgear pump or pump control must not be modified in any way without authorization from Oilgear. Modifications may not comply with safety standards, including ANSI safety standards, and may result in serious personal injury. Please contact Oilgear if you require assistance.

WARNING

DO NOT enter under hydraulic supported equipment unless they are fully supported or blocked. Failure to follow this procedure can result in serious injury or death.

WARNING

Any Oilgear pump safety decals must be replaced anytime they are damaged, missing or cannot be read clearly. Failure to have proper decals in place can result in serious injury or death. (If you require safety decals, please contact Oilgear for replacement safety decals, at no charge.)

WARNING

Be sure everyone is clear of the area around the hydraulic system before operating after servicing. Remain attentive at all times when operating to check your work until you are completely sure it is safe to return to service. Failure to heed this warning may result in serious personal injury or death.

WARNING

Wear the proper protective clothing when operating, servicing or maintaining the hydraulic system or the Oilgear pump. Wear the correct protective gear, safety glasses, gloves and safety shoes. Serious injury can result without proper protective gear.

WARNING

Make sure to keep hands, feet and other parts of your body clear of revolving or moving parts. Failure to comply can cause serious injury.

WARNING

DO NOT wear watches, rings or jewelry while working with electrical and mechanical equipment. These items can be hazardous and can cause serious and painful injuries if they come into contact with electrical wires, moving parts or hydraulic equipment.

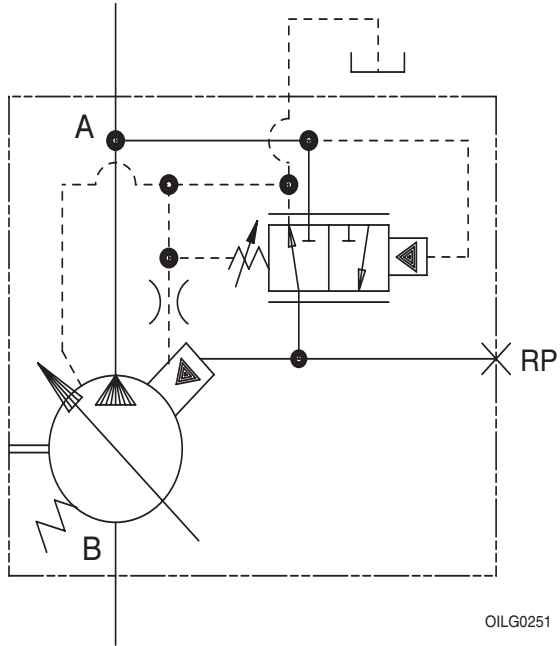

Figure 2. ASA Diagram for “P-1NN” or “P-LNN” Controls Shown with Typical Pump

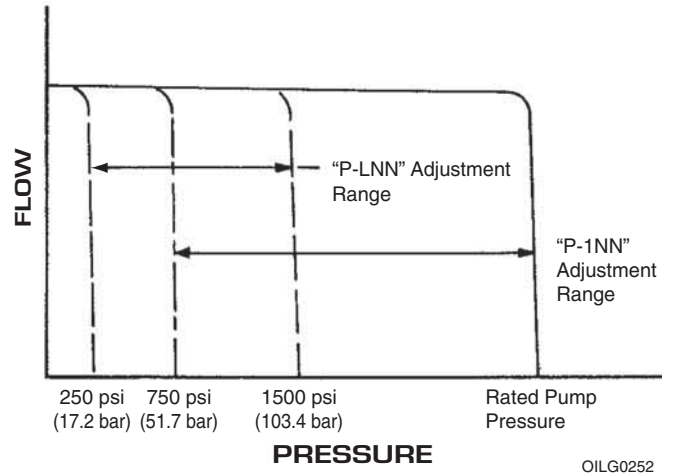

Figure 3. Curve Indicating Flow Versus Pressure for “P-1NN” or “P-LNN” Type Controls

TROUBLESHOOTING

PROBLEM	CAUSES	REMEDY
Unresponsive or Unstable Control	Swashblock bearing surface and/or Saddle Bearings worn or damaged.	See appropriate pump service bulletin.
	Control Pin and/or hole in Swashblock worn significantly.	
	Saddle Bearing Locating Pins broken.	
	Fluid is contaminated.	Inspect and clean if necessary. See bulletin 90007.
	Control Piston orifice (732) plugged.	Inspect and clean if necessary.
	Contamination trapped between control piston (702) and piston bore is not allowing piston to move smoothly.	Inspect and clean if necessary. Replace scored or damaged parts.
	Contamination trapped between control spool (706) and spool bore is not allowing spool to move smoothly.	
	Faulty remote pressure compensator circuit components.	Inspect and replace if necessary.
	Hydraulic line between remote pressure compensator components and RP port of control is too long.	Shorten line length.
	Insufficient control flow.	Increase size of control piston orifice (732).
Insufficient Outlet Volume	Swashblock not stroking to desired displacement.	See appropriate pump service bulletin.
	Low input drive speed.	
	Worn or grooved Cylinder Barrel and/or Valve Plate mating surfaces.	
	Failed Driveshaft.	
	Worn or damaged Piston Shoes or Swashblock.	
	Worn Pistons and/or piston bores.	
	Control Piston stuck off stroke.	Inspect and replace if necessary.
	Maximum Volume Stop adjusted incorrectly.	Adjust Maximum Volume Stop CCW to increase outlet flow.
Pressure Compensator is set too close to operating pressure.	Adjust Pressure Compensator setting CW to increase setting.	
Destrokes at low pressure	Pressure compensator adjustment not set correctly.	Adjust Pressure Compensator setting CW to increase setting and retorque jam nut (715).
	Control Piston orifice (732) plugged.	Inspect and clean if necessary.
	Damaged or fractured control spring (items 708 and/or 709).	Inspect and replace if necessary.
	Severely worn control spool (706) and/or spool bore.	
	Damaged or fractured control piston spring (item 703).	
Faulty remote pressure compensator circuit components.		
Excessive peak pressure	Pressure Compensator is set too high.	Adjust Pressure Compensator setting CCW to decrease setting.
	Minimum Volume Stop is set too high.	Adjust Minimum Volume Stop CCW to decrease outlet flow.
	Fluid is contaminated.	Inspect and clean if necessary. See bulletin 90007.
	Swashblock bearing surface and/or Saddle Bearings worn or damaged.	See appropriate pump service bulletin.
	Contamination trapped between control piston (702) and piston bore is not allowing piston to move smoothly.	Inspect and clean if necessary. Replace scored or damaged parts.
	Contamination trapped between control spool (706) and spool bore is not allowing spool to move smoothly.	
	Hydraulic line between remote pressure compensator components and RP port of control is too long.	Shorten line length.
	Faulty remote pressure compensator circuit components.	Inspect and replace if necessary.
	Restriction in drilled passages between pump outlet port and control spool.	Inspect and clean if necessary.

PRINCIPLE OF OPERATION

The pressure compensator control ensures maximum pump flow until the system reaches the controls preset pressure setting. The control then regulates the pump output flow to match the flow requirements of the system, while maintaining the preset output pressure.

When the system pressure exceeds the compensator control setting, or the system no longer requires flow, the control de-strokes the pump while maintaining the preset pressure.

“P-1NN” controls can be adjusted from 750 psi (51,7 bar) working pressure up to the maximum pressure rating of the applicable pump. “P-LNN” controls can be adjusted from 250 psi (17,2 bar) up to a maximum of 1500 psi (103,4 bar).

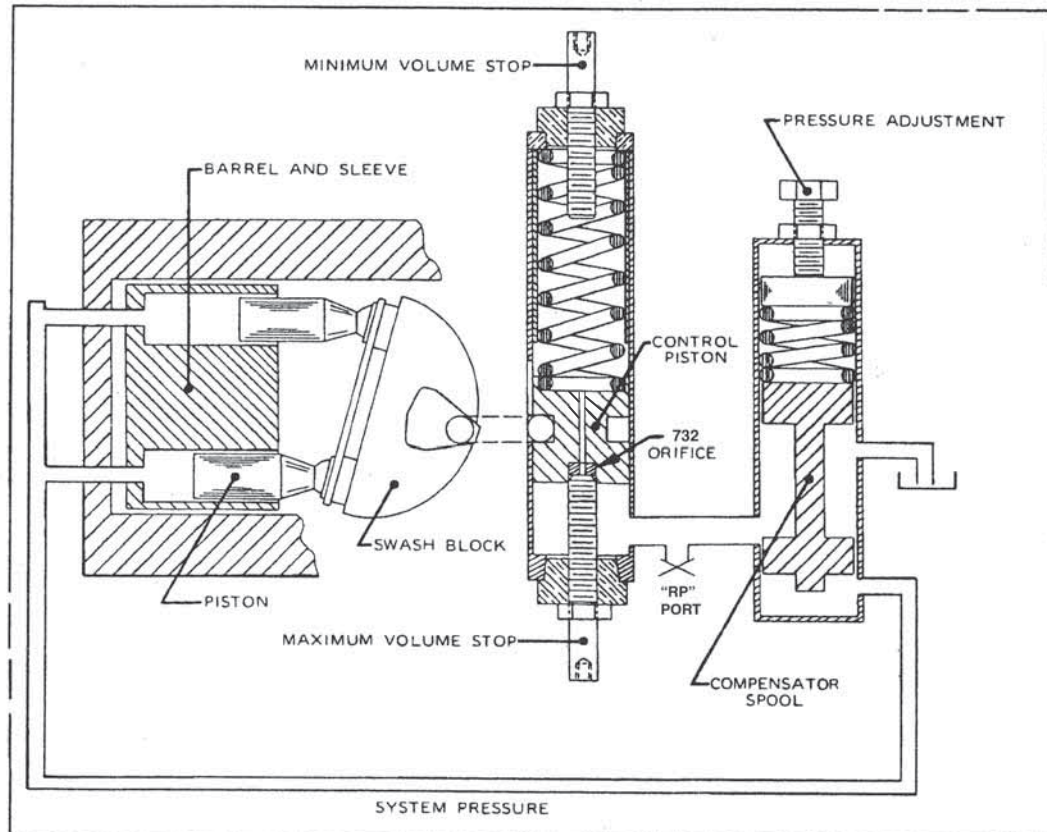

OILG0253

Figure 4. Swashblock at Full Delivery and “P-1NN” or “P-LNN” Controls at Maximum Volume Stop

LINE MOUNTED REMOTE PRESSURE CONTROL FOR TYPE “P-1NN” AND “P-LNN” PUMP CONTROLS - VSR (REMOTE SEQUENCE VALVE)

Remote operation of “P-1NN” and “P-LNN” controls can be accomplished by installing an Oilgear VSR Module at the location shown in the control circuit. Use module L51542 for units rated continuously for 4000 psi (275,8 bar) or less. Use L51542-1 for units rated above 4000 psi (275,8 bar).

NOTE *To minimize case leakage and power loss, plug the control drain port with a #10-24 UNC setscrew to maintain the standard “P-1NN” or “P-LNN” control case leakage. The plug will increase response time. Standard response time can be obtained by installing a .040 inch (1,0 mm) orifice instead of plugging it.*

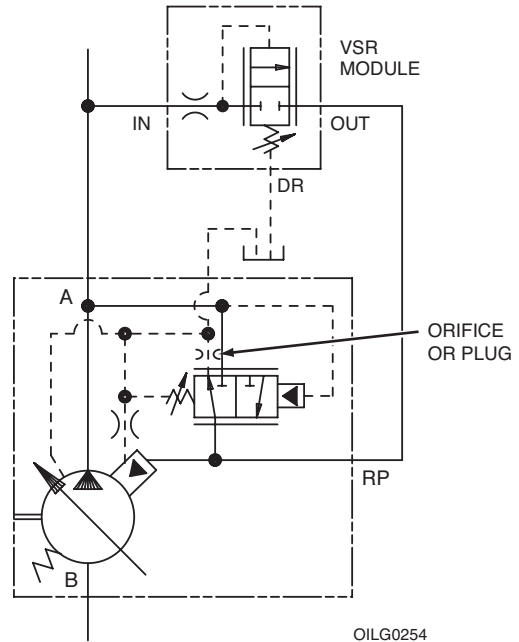

Figure 5. “P-1NN” and “P-LNN” Control Circuit with Remote Pressure Control

DRAIN PORT AS VIEWED FROM UNDERSIDE OF CONTROL BODY.

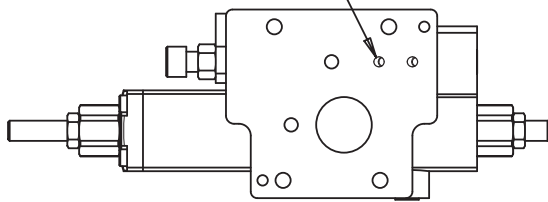

Figure 7. “P-1NN” and “P-LNN” Control Drain Port Location

NOTE *The compensator setting on the pump control must be set at least 200 psi (13,8 bar) higher than the required pressure setting of the remote compensator module to prevent the pump compensator control from interacting with the remote compensator module.*

**SCREW AND PLUG TORQUES
FOR CONTROLS**

Item Number	Description	Head Type & Size	Tightening Torque
601	SAE #2 Plug	1/8" Internal Hex	45 in.-lbs (5 N·m)
603	SAE #4 Plug	3/16" Internal Hex	120 in.-lbs (14 N·m)
606	SAE #8 Plug	5/16" Internal Hex	45 ft-lbs (61 N·m)
711	PC Adjuster Screw LHCS	3/32" Internal Hex	57 in.-lbs (6 N·m)
714	Adjuster Plate Screw	5/32" Internal Hex	80 in.-lbs (9 N·m)
720	Max. or Min. Volume Stop Housing	7/8" External Hex	50 ft-lbs (68 N·m)
722	End Cap Screws	3/16" Internal Hex	120 in.-lbs (14 N·m)
723	Control Body Screws	3/16" Internal Hex	120 in.-lbs (14 N·m)
732	Control Piston Orifice	3/32" Internal Hex	20 in.-lbs (2.3 N·m)

CONTROL O-RING SEALS

Item Number	ARP 568 Uniform Size Number	Shore A Durometer
1010	-010	90
1011	-011	90
1113	-113	90
1125	-125	90
1237	-237	70
1902	-902	90
1904	-904	90
1908	-908	90

B-Frame PVWJ -025/-034/-046 “P-1NN” and “P-LNN”

PARTS LIST

Parts used in these assemblies are per Oilgear specifications. Use only Oilgear parts to ensure compatibility with assembly requirements. When ordering replacement parts, be sure to include pump type and serial number, bulletin number and item number. Specify type of hydraulic fluid to ensure seal and packing compatibility.

NOTE *Parts drawings may not be identical to Oilgear drawings referenced.*

PVWJ-025/-034/-046 PRESSURE COMPENSATOR CONTROLS (“P-1NN” STANDARD & “P-LNN” LOW PRESSURE CONTROLS)

Item	Description
COMMON PARTS GROUP	
601	SAE#2 Plug
603	SAE#4 Plug
606	SAE#8 Plug
701	Control Block
702	Control Piston
703	Control Piston Spring
704	Piston Stop
705	End Cap
706	Pressure Compensator Control Spool
707	Spring Seat
708	Pressure Compensator Spring (Outer)
709*	Pressure Compensator Spring (Inner)
710	Control Plug
711	Screw
712	Shims
713	Adjuster Plate
714	Screw
715	Jam Nut
716	Pressure Compensator Adjustment Screw
717	Min. Volume Stop Stem
718	Max. Volume Stop Stem
719	Jam Nut
720	Volume Stop Housing
721	Control Pin
722	Screw, End Cap
723	Screw, Control Body
732	Orifice
1010	O-Ring
1011	O-Ring
1113	O-Ring
1125	O-Ring
1237	O-Ring
1902	O-Ring
1904	O-Ring
1908	O-Ring

*Only used in P-1 Control.

B-Frame PVWJ -025/-034/-046 “P-1NN” and “P-LNN”

SERVICE KITS

Document Number: 519975-SK2

PVWJ Service Kits

Revision: New

Reference 519975-201
SERVICE KIT, Figures 8 & 9

Description	Kit No.	Design Series	Items Included (quantity is 1 unless noted)
Main Control Body Kits			
PVWJ-025	K50432-100	A1	701, 706
PVWJ-034/-046	K50432-200	A1	701, 706
Control Piston Kits			
All Models	K50484	A1	702, 732
Pressure Compensator Spools			
PVWJ-025	50015-100	A1	706
PVWJ-034/-046	50015-200	A1	706
Control Spring Kits			
P-LNN (All Models)	K50036-104	A1	703, 708
PVWJ-025 P-1NN	K50036-107	A1	703, 708
PVWJ-034/-046 P-1NN	K50036-110	A1	703, 708, 709
Control Pins			
All Models	51339-5	A1	721
Volume Stop Kits			
Maximum Volume Stop (All Models)	K50590	A1	718, 719, 720, 1011, 1908
Minimum Volume Stop (All Models)	K50590-200	A1	705, 717, 719, 720, 1011, 1020, 1908
Pressure Compensator Adjuster Kits			
All Models	K50660-200	A1	710, 711, 712, 713, 715, 716, 1113
Control Seal Kit			
All Models	K50824-200	A1	1010, 1011, 1113, 1125, 1237, 1902, 1904, 1908

B-Frame PVWJ -025/-034/-046 “P-1NN” and “P-LNN”

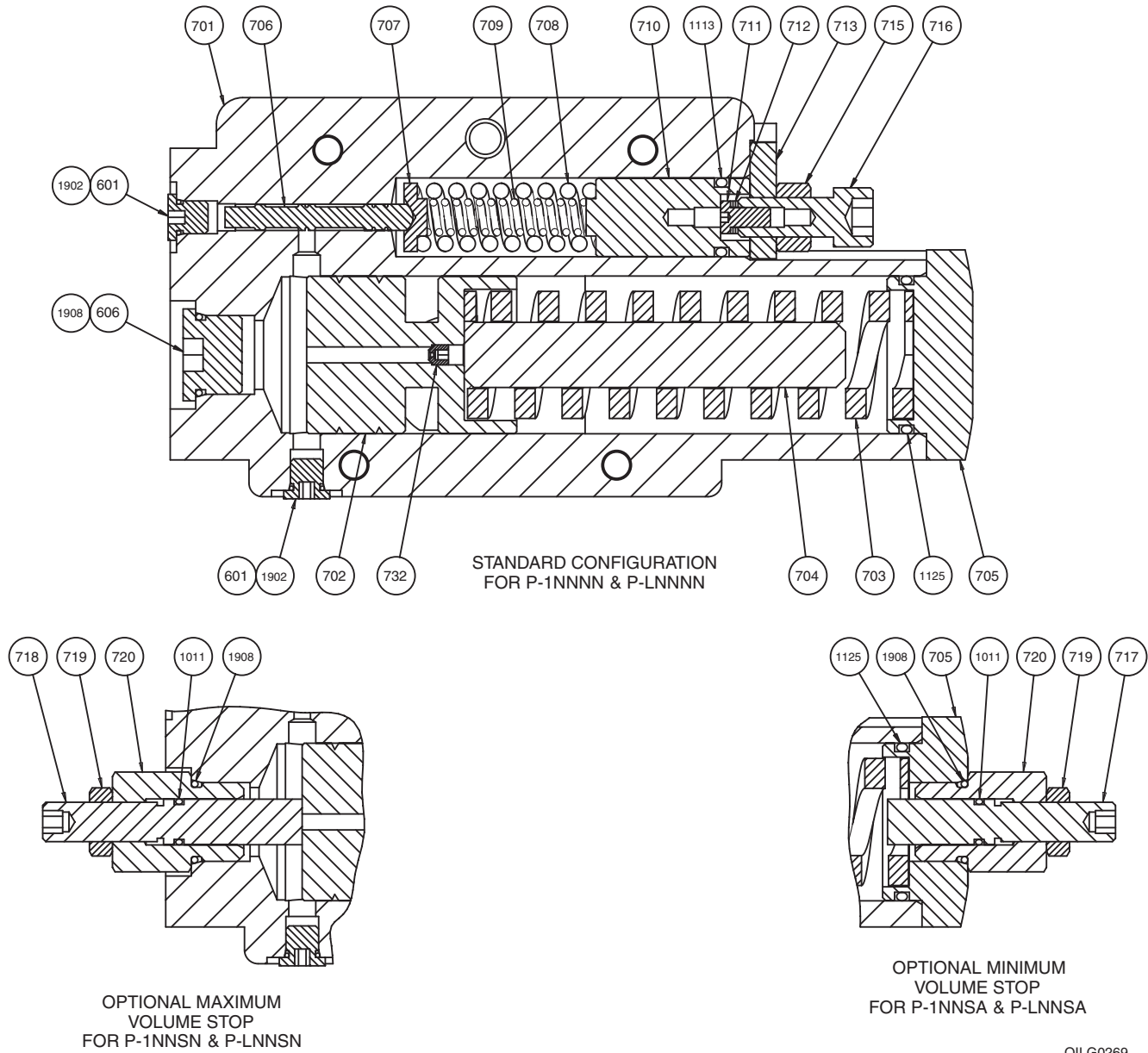

Figure 8. Parts Drawing for “P-1NN” and “P-LNN” Control (519975-201 sheet 1)

MAXIMUM AND MINIMUM VOLUME STOP

The maximum volume stop can be adjusted to attain a maximum volume from full to 25% of full flow. The pump can be de-stroked from full to 25% flow with 11 turns of the volume stop. One turn clockwise will decrease maximum pump outlet flow 7%.

The minimum volume stop can be adjusted to attain a minimum volume from zero to full flow. The adjustment requires 14 turns to go from zero to full flow. One turn clockwise will increase minimum pump outlet flow 9%.

OILG0269

B-Frame PVWJ -025/-034/-046 "P-1NN" and "P-LNN"

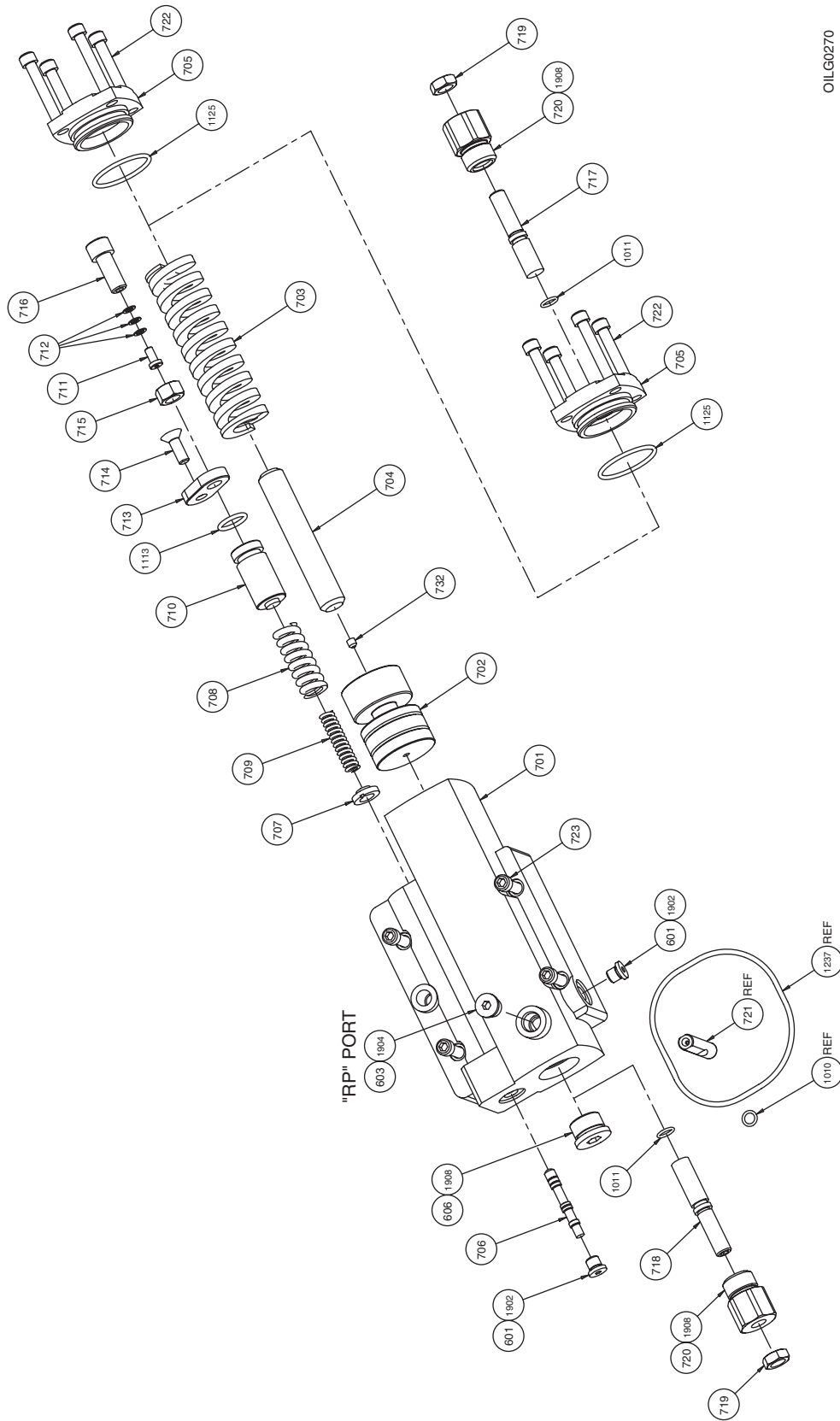

OILG0270

Figure 9. Exploded Parts Drawing for "P-1NN" and "P-LNN" Control (519975-201 sheet 2)

AFTER SALES SERVICES

At Oilgear we build products to last. It is the nature of this type of machinery to require proper maintenance regardless of the care we put into manufacturing. Oilgear has several service programs in place to help you.

STAY-ON-STREAM SERVICE

By signing up for Oilgear's Stay-On-Stream program, you can prepare for problems before they happen. Certain field tests such as fluid testing, slip testing and electronic profile recording comparisons can be performed by our field service people or your own factory trained personnel. These tests can indicate problems before they become "down-time" difficulties.

SERVICE SCHOOLS

Oilgear conducts training to train your maintenance personnel. "General" hydraulic or electronic training is conducted at our Milwaukee, Wisconsin plant on a regular basis. "Custom" training, specifically addressing your particular hydraulic and electro-hydraulic equipment, can be conducted at your facilities.

SPARE PARTS AVAILABILITY

Prepare for your future needs by stocking Oilgear original factory parts. Having the correct parts and necessary skills "in-plant" enables you to minimize "down-time." Oilgear has developed parts kits to cover likely future needs. Oilgear Field Service Technicians are also ready to assist you and your maintenance people in troubleshooting and repairing equipment.

