

SERVICE INSTRUCTIONS

“P-CNN/H” SINGLE PRESSURE - SOFT START WITH HORSEPOWER LIMITER, SERIES F1U CONTROL

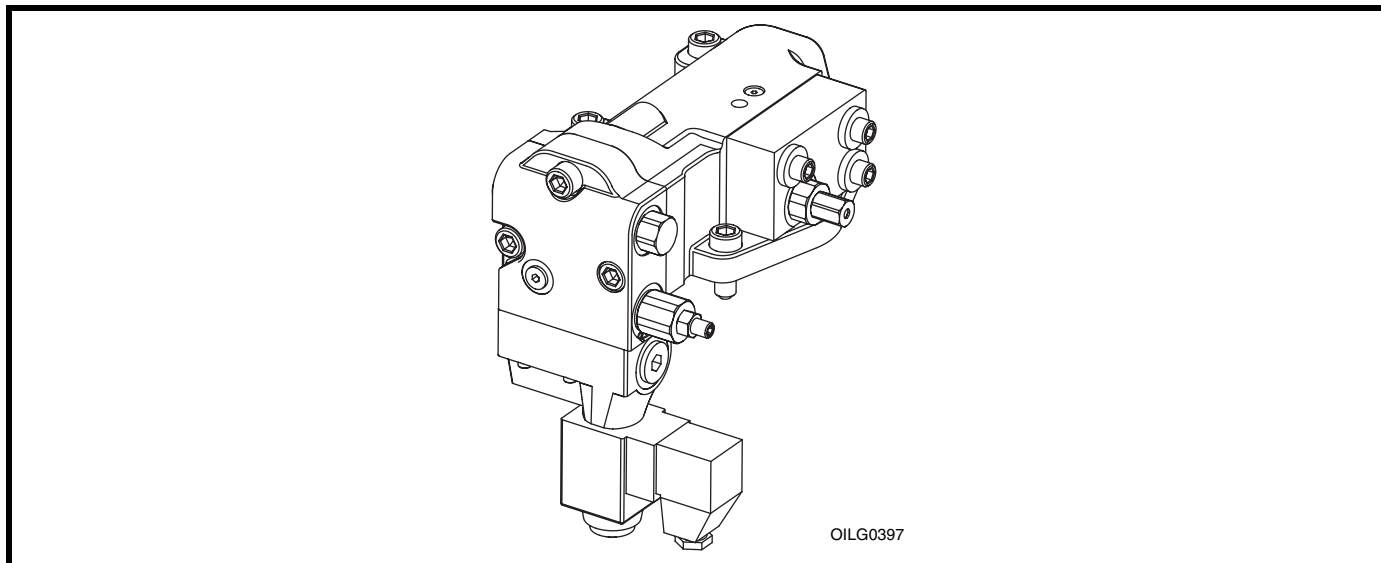

Figure 1. Typical Oilgear Type “P-CNN/H” Single Pressure - Soft Start with Horsepower Limiter, Series F1U Control for “PVG” 100/130 (F1U Series) Pumps

PURPOSE OF INSTRUCTIONS

These instructions will simplify the installation, operation, troubleshooting and maintenance of Oilgear type “P-CNN/H” Single Pressure - Soft Start with Horsepower Limiter, Series F1U controlled units.

This material will inform you about the basic construction, principle of operation and service parts listings. Some controls may be modified for specific applications from those described in this bulletin and other changes may be made without notice.

REFERENCE MATERIAL

- Fluid RecommendationsBulletin 90000
- Contamination Evaluation Guide.....Bulletin 90004
- Filtration RecommendationsBulletin 90007
- Piping InformationBulletin 90011
- Installation of Vertically Mounted Axial Piston UnitsBulletin 90014
- PVG Pumps - 100/130 (F1U Series) Service InstructionsBulletin 947022
- PVG Open Loop Pumps, SalesBulletin 47019-H

PVG SERIES F1U PUMP INSTALLATIONS

- Horsepower Limiter, Single Pressure - Soft Start “P-CNN/H” Data Sheet 47521
- Rear Ported Basic Pump, Installation Data Sheet 47942C
- Side Ported Basic Pump, Installation Data Sheet 47943C
- Through Shaft Basic Pump, Installation Data Sheet 47944C
- Gear Pump, Installation..... Data Sheet 47945
- Dual Pump Adapters, Installation..... Data Sheet 47946

THE OILGEAR COMPANY

2300 South 51st Street
Milwaukee, Wisconsin 53219
www.oilgear.com

Safety First

Read and understand this entire instruction sheet before repairing or adjusting your Oilgear product.

Those who use and maintain this equipment must be thoroughly trained and familiar with the product. If incorrectly used or maintained, this product and its equipment can cause severe injury.

SAFETY SYMBOLS

The following signal words are used in this instruction sheet to identify areas of concern where your safety may be involved. Carefully read the text and observe any instructions provided to ensure your safety.

DANGER

THIS SIGNAL WORD INDICATES AN IMMEDIATELY HAZARDOUS SITUATION WHICH, IF NOT AVOIDED, WILL RESULT IN DEATH OR SERIOUS INJURY.

WARNING

This signal word indicates a potentially hazardous situation which, if not avoided, could result in death or serious injury.

CAUTION

This signal word indicates that a potentially hazardous situation exists which, if not avoided, may result in damage to equipment or minor personal injury.

NOTE

While not directly relevant to the topic being discussed, the NOTE is used to emphasize information provided, or provide additional information which may be of benefit.

WARNING

This service information is designed for the maintenance of your Oilgear product. It contains the information on the correct procedures determined by Oilgear for the safe manner of servicing. Always keep this instruction sheet in a location where it is readily available for the persons who use and maintain the product. Additional copies of this instruction sheet are available through Oilgear. Contact us at 414-327-1700 or visit our website: www.oilgear.com. Please contact us if you have any questions regarding the information in this instruction bulletin.

NOTE

The cleanliness of working on this pump control or the hydraulic system is extremely important to the safety and reliability of the pump and the system. Always make sure the fittings are clean on the outside before removing them from their connections, are capped and plugged when removed, and are placed in a clean rag or container until they are reinstalled.

WARNING

Some service operations may require special tools or equipment. If you require information on these items, please contact Oilgear before attempting these repairs and service operations.

WARNING

Read, understand and follow the safety guidelines, dangers and warnings contained in this instruction sheet to promote reliable operation and prevent serious personal injury.

WARNING

DO NOT attempt to service this machinery in an environment where safety regulations are not established and in place.

WARNING

DO NOT operate the hydraulic system if a leak is present. Serious injury may result.

WARNING

Hydraulic systems operate under very high pressure. Hydraulic fluid escaping from a pressurized system can penetrate unprotected body tissue. DO NOT inspect for hydraulic leaks with bare hands or other exposed body parts. As a minimum, wear leather gloves prior to inspecting for leaks and use cardboard or wood. If leaks are present, relieve pressure and allow system to cool prior to servicing. If injured by escaping hydraulic oil, contact a physician immediately. Serious complications may arise if not treated immediately. If you have questions regarding inspecting for hydraulic leaks, please contact Oilgear prior to servicing.

⚠ WARNING

Hydraulic hoses and tubing must be inspected on a daily basis for leaks, cuts, abrasions, damage and improper clearance along any mounting frame for hidden damage before the unit is put into service. Replace damaged hoses or hoses you suspect are damaged before the system is returned to service! Hoses must be replaced every 2 years. Failure to properly inspect and maintain the system may result in serious injury.

⚠ WARNING

Hydraulic systems are hot. **DO NOT TOUCH!** Serious personal injury may result from hot oil. When you have completed working on the hydraulic system, thoroughly clean any spilled oil from the equipment. Do not spill any hydraulic fluids on the ground. Clean any hydraulic fluids from your skin as soon as you have completed maintenance and repairs. Dispose of used oil and system filters as required by law.

⚠ WARNING

Use hoses, fittings and adapters with the correct SAE rating when replacing hoses to prevent possible serious injury. Always replace hoses, fittings and adapters with replacements that have a proper, suitable, working pressure rating. Replacement hoses must be of the correct length and must comply with the hose manufacturer's and Oilgear's installation guidelines and recommendations.

⚠ WARNING

Hydraulic hoses have the SAE ratings marked on the hose to assist you in selecting the correct hose. The same manufacturer must supply any replacement hydraulic hoses and fitting assemblies. As an example: Brand "X" hose and brand "Y" fitting will not normally be compatible. No "Twist" is allowed in the hydraulic hoses. "Twist" may result in premature hose failure. This can cause serious injury. Please contact Oilgear for assistance when required.

⚠ WARNING

Hydraulic cylinders can be holding a function in a certain position when the pump is off. An example of this is a function being held in the lift or partial lift position by the cylinders. If a hydraulic line is removed or the hydraulic circuits or controls are being worked on, gravity may allow the function being held in position to drop. All workers and personnel must remain clear of these areas when working on or operating the hydraulic system. Block and secure all devices and functions which apply before beginning work or operation. Failure to comply with this can result in serious injury or death.

⚠ WARNING

Any hydraulic pipe which is replaced must conform to SAE J1065 specifications. If incorrect hydraulic pipe is installed, the hydraulic system may fail, causing serious injury. Damaged or leaking fittings, pipes or hoses must be replaced before the system is returned to service.

⚠ WARNING

DO NOT heat hydraulic pipe. The carbon content of this steel tube is such that if heated for bending, and either water or air quenched, the pipe may lose its ductility and thereby be subject to failure under high pressure conditions. Serious injury can result. Damaged or leaking pipes must be replaced before the system is returned to service. Please contact Oilgear if you require assistance or have questions.

⚠ WARNING

All hydraulic pressure must be relieved from the hydraulic system prior to removing any components from the system. To relieve the hydraulic pressure from the hydraulic system, turn off the motor and operate the control panel with the key in the ON position. Failure to comply can result in serious injury. If you have any questions concerning relieving the hydraulic pressure from the system, please contact Oilgear.

WARNING

Hydraulic components can be heavy. Use caution while lifting these components. Serious personal injury can be avoided with proper handling of the components.

WARNING

Please contact Oilgear if you require assistance. When performing hydraulic test procedures, use the proper hydraulic gauges. Installing an incorrect test gauge could result in serious injury if the gauge fails. Use properly rated hydraulic hoses to allow the test gauge to be read away from moving parts and functions.

WARNING

Increasing hydraulic pressure beyond the recommendations may result in serious damage to the pump and system or serious personal injury, and may void the Oilgear Warranty. If you have questions concerning hydraulic pressures or testing procedures, please contact Oilgear before attempting the test procedures or making adjustments.

WARNING

An Oilgear pump or pump control must not be modified in any way without authorization from Oilgear. Modifications may not comply with safety standards, including ANSI safety standards, and may result in serious personal injury. Please contact Oilgear if you require assistance.

WARNING

DO NOT enter under hydraulic-supported equipment unless it is fully supported or blocked. Failure to follow this procedure can result in serious injury or death.

WARNING

Any Oilgear pump safety decals must be replaced anytime they are damaged, missing or cannot be read clearly. Failure to have proper decals in place can result in serious injury or death. (If you require safety decals, please contact Oilgear for replacement safety decals, at no charge.)

WARNING

Be sure everyone is clear of the area around the hydraulic system before operating after servicing. Remain attentive at all times when operating to check your work until you are completely sure it is safe to return to service. Failure to heed this warning may result in serious personal injury or death.

WARNING

Wear the proper protective clothing when operating, servicing or maintaining the hydraulic system or the Oilgear pump. Wear the correct protective gear, safety glasses, gloves and safety shoes. Serious injury can result without proper protective gear.

WARNING

Make sure to keep hands, feet and other parts of your body clear of revolving or moving parts. Failure to comply can cause serious injury.

WARNING

DO NOT wear watches, rings or jewelry while working with electrical and mechanical equipment. These items can be hazardous and can cause serious and painful injuries if they come into contact with electrical wires, moving parts or hydraulic equipment.

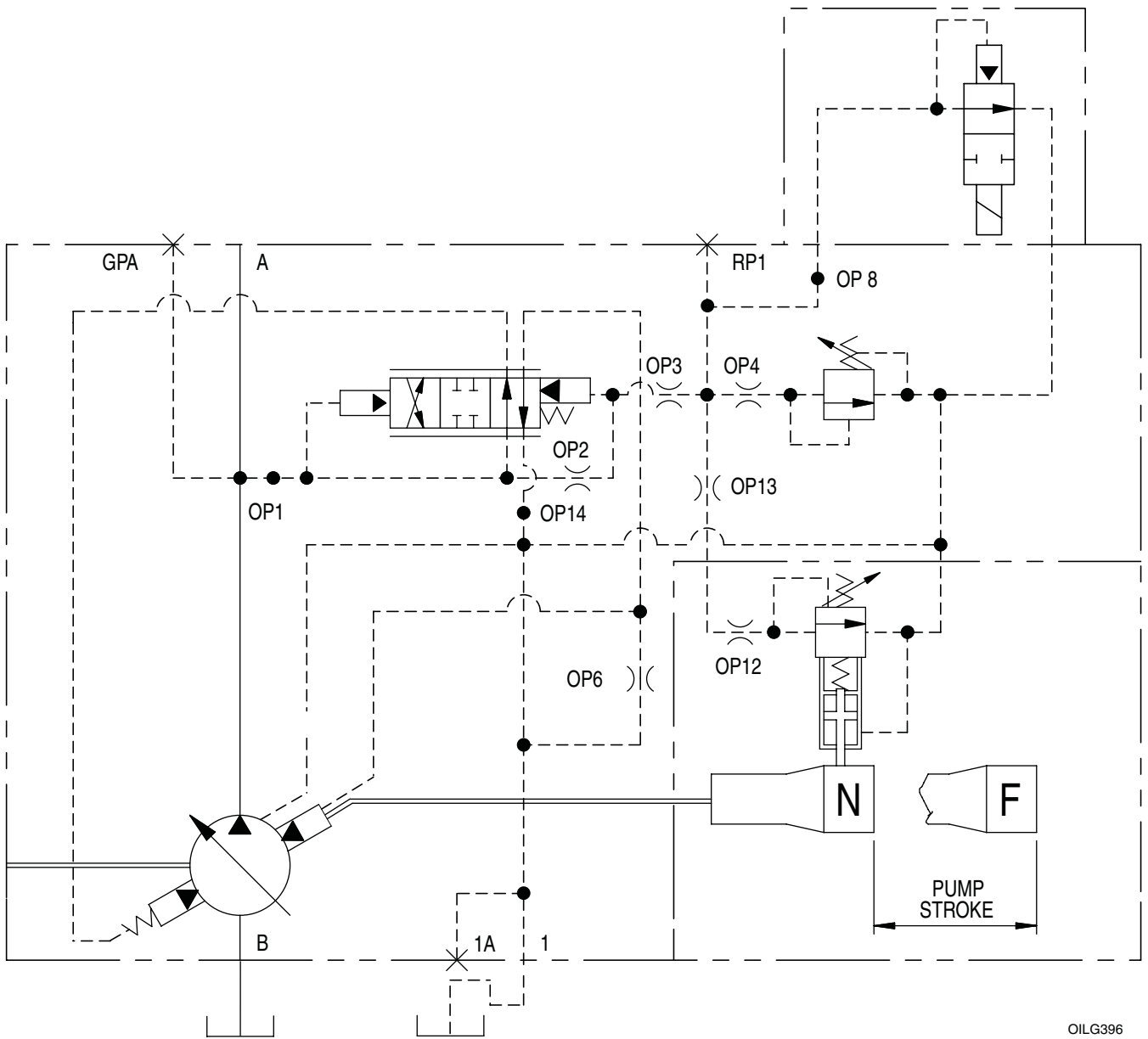

Figure 2. ASA Diagram for "P-CNN/H" Control Shown with Typical Pump

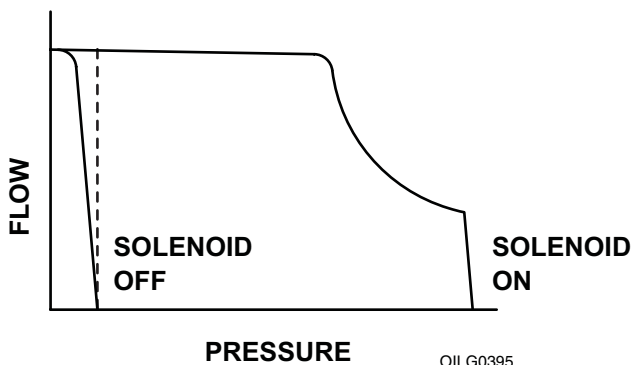

Figure 3. Curve Indicating Flow Versus Pressure for "P-CNN/H" Type Control

TROUBLESHOOTING

PROBLEM	CAUSES	REMEDY
Unresponsive or Unstable Control	Swashblock bearing surface and/or saddle bearings worn or damaged	Refer to 947022 Pump Service Instructions.
	Guide plate damaged	
	Fluid is contaminated	Inspect and clean if necessary. Refer to Filtration Recommendations Bulletin 90007.
	Contamination trapped between control piston and bore not allowing piston to move smoothly	Inspect and clean if necessary. Replace damaged parts.
	Contamination trapped between control spool and bore not allowing spool to move smoothly	
	Insufficient control flow	Increase size of control orifice "OP 6.
	Worn or damaged pilot relief seat and/or poppet	Inspect and replace if necessary.
	Faulty remote function circuit	
Hydraulic line between remote function and pump port RP1 is incorrect	Change hydraulic line.	
Insufficient Outlet Volume	Swashblock bearing surface and/or saddle bearings worn or damaged	Refer to 947022 Pump Service Instructions.
	Guide plate damaged	
	Low input drive speed	
	Worn cylinder barrel and/or valve plate mating surfaces	
	Failed drive shaft	
	Worn or damaged piston shoes and/or swashblock	
	Worn pistons and/or piston bores	Adjust maximum volume stop CCW to increase flow.
	Maximum volume stop adjusted incorrectly	
	Pressure compensator is set too close to operating pressure	Adjust pressure compensator CW to increase pressure.
	Improper horsepower setting	Requires factory adjustment
	Worn or damaged horsepower valve	Requires factory service
	Control piston stuck off stroke	Inspect and replace if necessary.
Faulty remote function circuit		
Unable to Develop Full Pressure	System requires more flow than available	Check system for leaks or open functions.
	Pressure compensator adjustment not set correctly	Adjust pressure compensator CW to increase pressure.
	Improper horsepower setting	Requires factory adjustment
	Worn or damaged horsepower valve	Requires factory service
	Contamination in control spool	Inspect and clean if necessary.
	Worn or damaged pilot relief seat and/or poppet	Inspect and replace if necessary.
	Pressure selector valve seat and/or poppet worn or damaged	
	Pressure selector valve solenoid damaged	
Control piston stuck off stroke		
Faulty remote function circuit		

TROUBLESHOOTING

PROBLEM	CAUSES	REMEDY
Excessive Pressure	Swashblock bearing surface and/or saddle bearings worn or damaged	Refer to 947022 Pump Service Instructions.
	Guide plate damaged	
	Pressure compensator adjustment not set correctly	Adjust pressure compensator CCW to decrease pressure.
	Improper horsepower setting	Requires factory adjustment
	Contamination in "OP 3", "OP 4", "OP 12" or "OP 13"	Inspect and clean if necessary.
	Contamination in pressure selector valve seat	
	Restricted passage between outlet and control spool	
	Contamination trapped between control piston and bore not allowing piston to move smoothly	Inspect and clean if necessary. Replace damaged parts.
	Contamination trapped between control spool and bore not allowing spool to move smoothly	
Faulty remote function circuit	Inspect and replace if necessary.	

GENERAL

Operation for a typical pump is described. Section diagrams are a representation of typical pumps with "P-CNN/H" control.

Functionally, the swashblock (and resultant delivery) is positioned by two opposite (acting) control pistons.

See control parts drawing for actual configuration and location of part assemblies, orifices, connections and ports.

PRINCIPLE OF OPERATION

STARTING

The bias control piston spring positions the control and connected pump swashblock so that the pump will deliver maximum volume to raise pressure in the system.

RAISING PRESSURE (LOADING)

Pump delivery (and resultant pressure) is fed back to the control through Port "OP 1." The pressure compensating spool (305) is held in position by a pilot control valve spring (328). Flow (and resultant pressure) is transmitted through the pressure compensating spool (305) to the area behind the bias control piston and through orifice Port "OP 2."

Pressure acting on either end of the pilot control valve is equal. The spool is balanced and held in position by the pilot control valve spring (328). Flow (and resultant pressure) is also transmitted through Port "OP 3" and Port "OP 4" to the adjustable control relief valve (310), through Port "OP 8" to the pilot vent valve and through Ports "OP 12" and "OP 13" to the horsepower control valve, which blocks further flow in the control (and pressure transmittal).

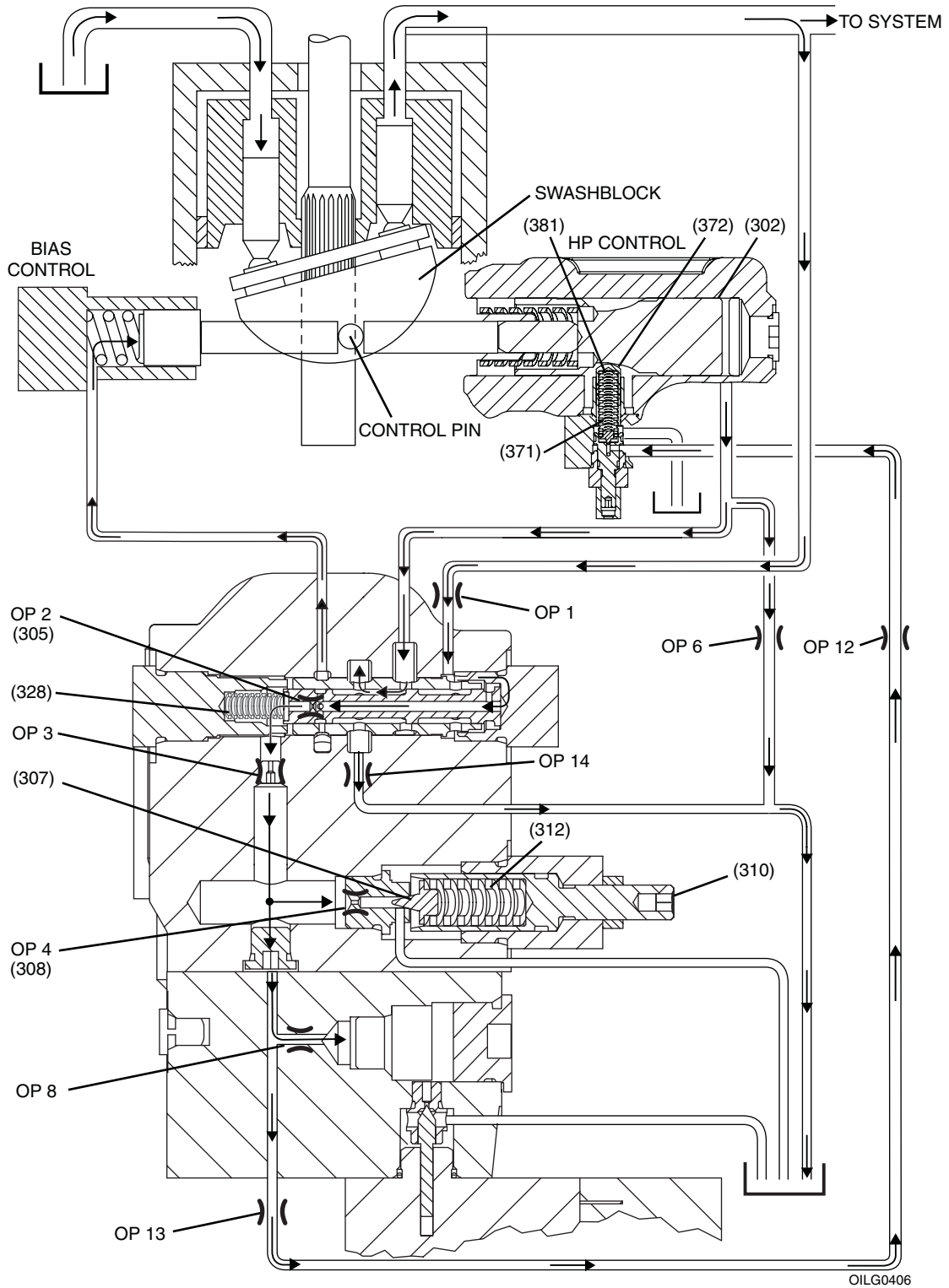

Figure 4. Raising Pressure (Loading)

COMPENSATING PRESSURE (UNLOADING) AT MINIMUM PRESSURE WITH PILOT VENT VALVE DEENERGIZED TO PASS FLOW

With vent valve open allowing flow through drain line to pump case and case drain, pressure is reduced on the spring end of the pressure compensating spool **(305)**.

Flow through "OP 2" reduces pressure on the spring end of the pressure compensating spool **(305)**. There is still full pressure on the other end of the pressure compensating spool. This differential pressure forces the pressure compensating spool **(305)** to shift and compress the control valve spring **(328)**. The pressure compensating spool now allows pump delivery (and resultant pressure) to flow to the unloading control piston. The pressure compensating spool simultaneously drains the fluid from behind the bias control piston.

The control piston now moves the control pin and shifts the swashblock to a position towards neutral, where the pump delivers sufficient volume to maintain minimum pressure.

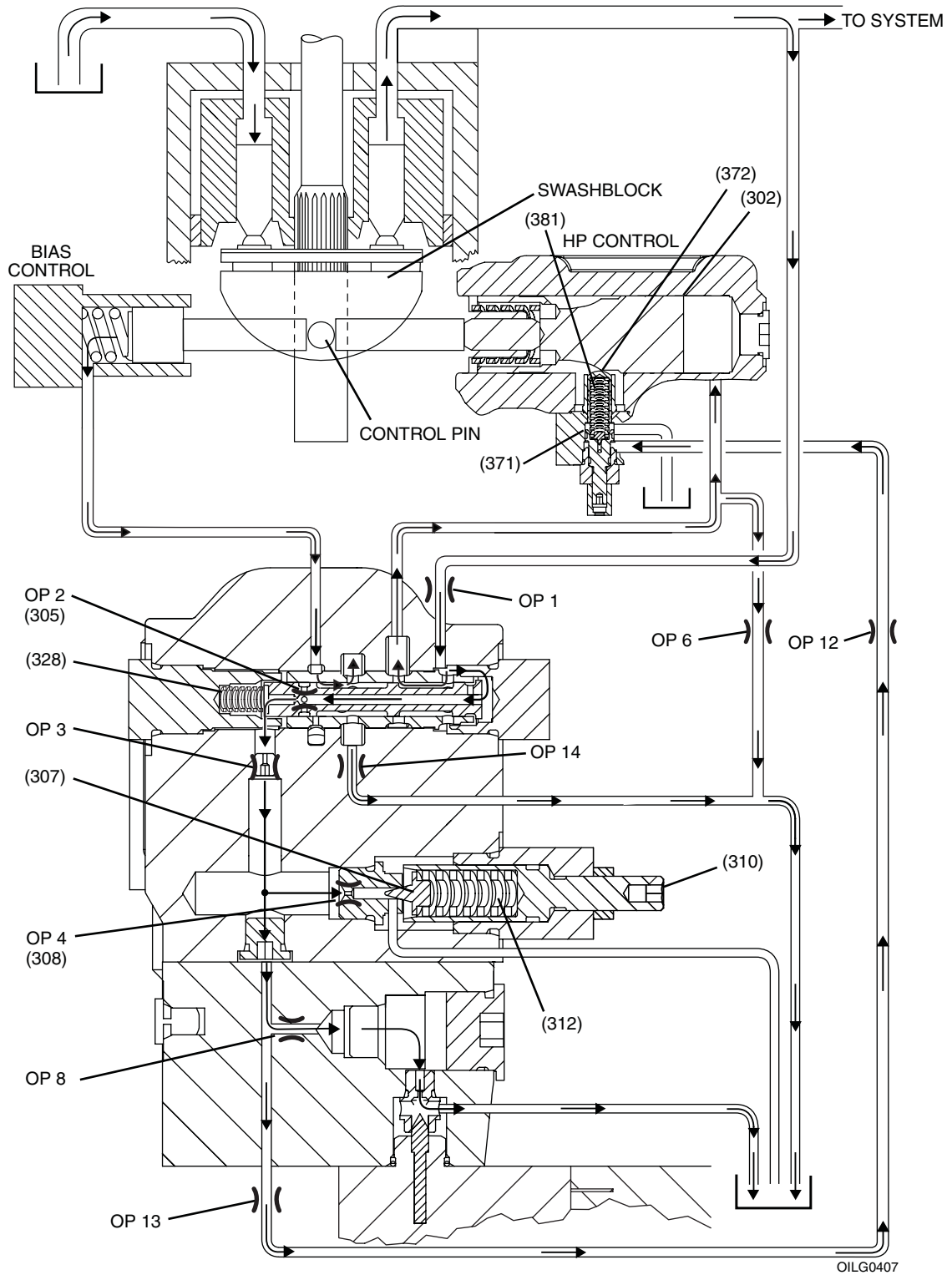

Figure 5. Compensating Pressure (Unloading) at Minimum Pressure with Pilot Vent Valve Deenergized to Pass Flow

COMPENSATING PRESSURE (UNLOADING) AT HIGHER PRESSURE WITH PILOT VENT VALVE ENERGIZED TO BLOCK FLOW

When pressure on the relief valve poppet **(307)** exceeds the presetting of the relief valve screw **(310)**: Set by turning the valve screw in or out, which sets the force of the relief valve spring **(312)**. The relief valve poppet **(307)** moves off seat **(308)** and allows flow through the valve, and through drain line to pump case and case drain. Pressure is reduced on the spring end of the pressure compensating spool **(305)**.

Flow through “OP 2” reduces pressure on the spring end of the pressure compensating spool **(305)**. There is still full pressure on the other end of the pressure compensating spool. This differential pressure forces the pressure compensating spool **(305)** to shift and compress the control valve spring **(328)**. The pressure compensating spool now allows pump delivery (and resultant pressure) to flow to the unloading control piston. The pressure compensating spool simultaneously drains the fluid from behind the bias control piston.

The control piston now moves the control pin and shifts the swashblock to a position towards neutral, where the pump delivers sufficient volume to maintain system pressure as regulated by the control relief valve **(310)**.

HOLDING PRESSURE

If the system pressure drops below preset compensating pressure, the relief valve poppet **(307)** seats and forces on the pressure compensating spool **(305)** are balanced, the pilot control valve spring **(328)** returns the spool to the original position **(Figure 4)**, swashblock position shifts, and the pump increases delivery until the relief valve screw **(310)** preset pressure is reached again.

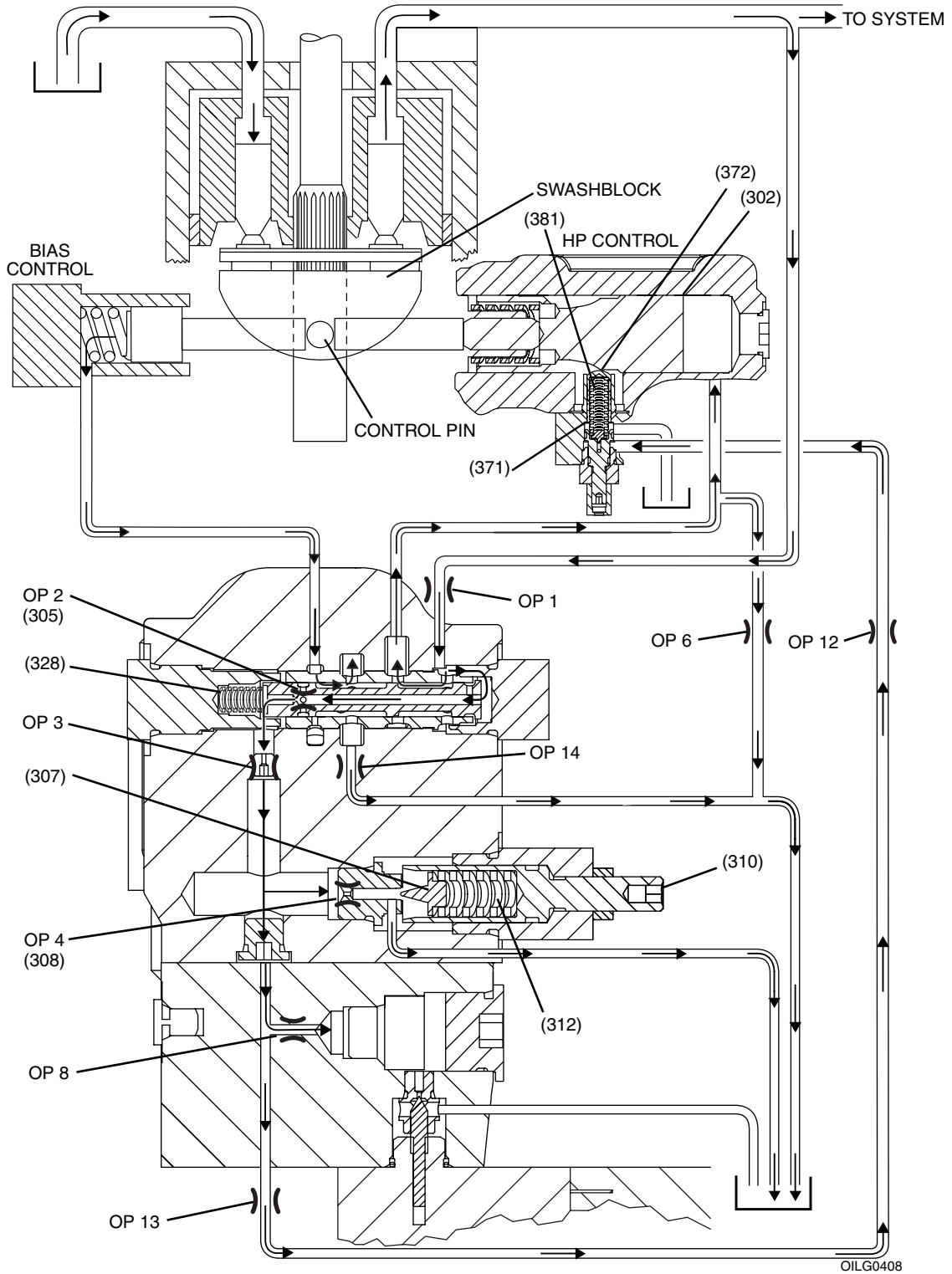

Figure 6. Compensating Pressure (Unloading) at Higher Pressure with Pilot Vent Valve Energized to Block Flow

COMPENSATING PRESSURE (UNLOADING) - HORSEPOWER LIMITER ACTIVE

A horsepower limiter is typically used when limited horsepower is available, and high volume at low pressure and low volume at high pressure are required.

Constant horsepower is related to flow and pressure. The flow is proportional to the swashblock angle. For a given swashblock angle, the cam on the control piston **(302)** adjusts the force on the horsepower valve through the cam follower **(372)** compressing spring **(381)**.

When the system pressure on the poppet **(371)** reaches the spring **(381)** force, the valve opens and flow across the valve generates a pressure drop across "OP 2." The unbalance of forces across the pressure compensating spool **(305)** shifts the spool, porting system pressure to the unloading control and draining the bias control.

The control piston moves until a control piston stroke is attained at the system pressure for constant horsepower setting of the control.

With decrease of system pressure, the horsepower valve poppet **(371)** reseats, blocking flow to drain. The compensating spool **(305)** will shift, causing the control piston to increase pump flow until constant horsepower is attained.

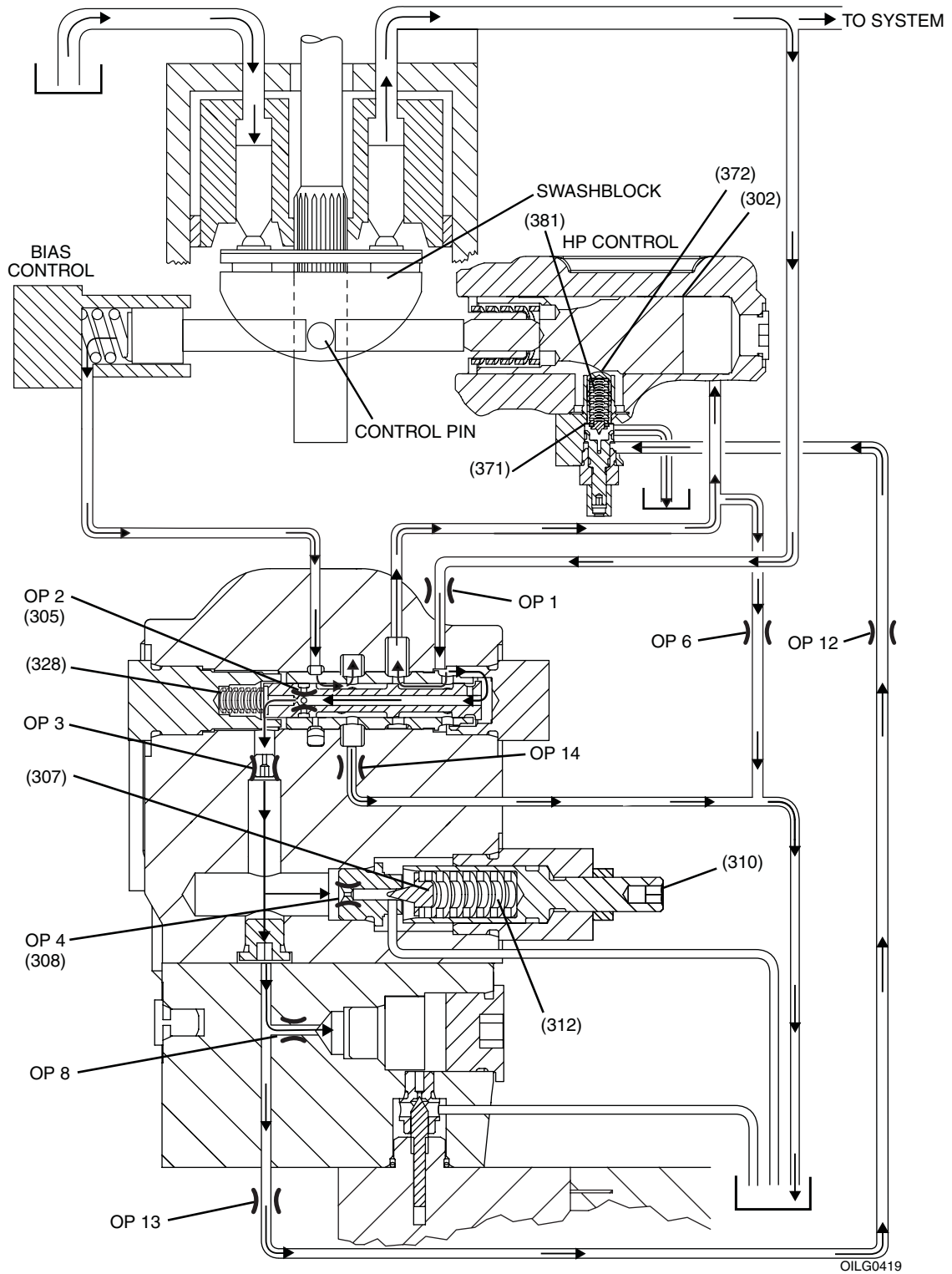

Figure 7. Compensating Pressure (Unloading) - Horsepower Limiter Active

ORIFICE FUNCTIONS

Orifice Number	Decreasing orifice diameter will result in: (increasing diameter will do the opposite)
"OP 1"	Do not decrease to less than .125"
"OP 2"	Do not change
"OP 3"	Do not change
"OP 4"	Do not change
"OP 6"	Decreased stability
"OP 8"	Increased stability
"OP 12"	Do not change
"OP 13"	Do not change
"OP 14"	Slowing down of "on stroke" time, do not decrease to less than .081"

"OP 1" Orifice not used (standard)

"OP 2" Integral to spool, item 305

"OP 4" Integral to seat, item 308

"OP 6" PVG 100 has .062 orifice in Port "OP 6"
 PVG 130 has .089 orifice in Port "OP 6"

"OP 8" Orifice not used (standard)

"OP 14" Orifice not used (standard)

SCREW AND PLUG TORQUES FOR “P-CNN/H” CONTROL

Item Number	Head Type & Hex Size	Tightening Torque
306	7/8 external	50 ft•lb (68 N•m)
308	7/16 external	200 in•lb (23 N•m)
309	1 external	80 ft•lb (108 N•m)
315	3/8 internal	100 ft•lb (136 N•m)
316A	3/8 internal	100 ft•lb (136 N•m)
316B	3/8 internal	100 ft•lb (136 N•m)
319	5/32 internal	48 in•lb (5 N•m)
320	1/8 internal	45 in•lb (5 N•m)
321	3/16 internal	120 in•lb (14 N•m)
322	7/8 external	50 ft•lb (68 N•m)
323	9/16 internal	120 ft•lb (163 N•m)
325	5/32 internal	48 in•lb (5 N•m)
342	1/8 internal	45 in•lb (5 N•m)
347	5/32 internal	48 in•lb (5 N•m)
371A	1/4 internal	200 in•lb (23 N•m)
373A	5/16 external	45 in•lb (5 N•m)
374	1 external	80 ft•lb (108 N•m)
375A	5/32 internal	57 in•lb (6 N•m)
377	5/16 internal	45 ft•lb (61 N•m)
383	5/32 internal	48 in•lb (5 N•m)
389	1/8 internal	45 in•lb (5 N•m)
391C	1 1/4 external	85 ft•lb (115 N•m)
396A	3/8 internal	70 ft•lb (95 N•m)

CONTROL O-RING SEALS

Item Number	ARP 568 Uniform Size Number	Shore A Durometer
313	-250	70
314	-136	70
330	-013	90
331	-014	90
332	-902	90
333	-906	90
334	-908	90
335	-910	90
336	-912	90
337	-014	*
338	-904	90
345	-903	90
374A	-902	90
378A	-906	90
379	-016	Teflon O-ring
380	-026	Teflon O-ring
384	-910	90
385	-013	90
386	-016	90
387	-013	*
388	-016	*
390	-902	90
393A	-907	90
394A	-117	90
394C	-014	90
395C	-912	90
396C	-014	*
397A	-910	90
398A	-010	90

* Teflon Backup Ring

PARTS LIST

Parts used in these assemblies are per Oilgear specifications. Use only Oilgear parts to ensure compatibility with assembly requirements. When ordering replacement parts, be sure to include pump type and serial number, and bulletin number and item number. Specify the type of hydraulic fluid to ensure seal and packing compatibility.

Item	Description	Qty
301	Control Housing	1
302	Control Piston	1
303	Reduced Area Piston	1
304	End Cap	1
305	Pressure Compensator Spool	1
306	End Plug	1
307	Poppet	1
308	Seat	1
309	Bonnet	1
310	Adjusting Screw	1
311	Control Pin	1
312	Shim	4
313	O-ring	1
314	O-ring	1
315	Screw	3
316A	Screw	2
316B	Screw	2
318	Jam Nut	1
319	Orifice	2
320	SAE #2 Plug	2
321	SAE #4 Plug	2
322	End Plug	1
323	SAE #12 Plug	1
325	Orifice	1
327	Spring	1
328	Spring	1
329	Spring	1
330	O-ring	4
331	O-ring	1
332	O-ring	2
333	O-ring	1
334	O-ring	2
335	O-ring	1
336	O-ring	1
337	Backup Ring	1
338	O-ring	2
340	Permanent Plug	1
342	SAE #3 Plug	1
345	O-ring	1
347	Orifice	1
348	Roll Pin	2
370	Control Housing	1
370A	D.C. Solenoid	1

Item	Description	Qty
371	Control Poppet	1
371A	SAE #6 Plug	1
372	Cam Follower	1
372A	Vent Valve Poppet	1
373	Adjusting Screw	1
373A	Vent Valve Seat	1
374	Control Bonnet	1
374A	O-ring	1
375	Tamper Resistant Cap	1
375A	Screw	4
376	Washer	3
376A	Vent Valve Module	1
377	Screw	3
378	Roll Pin	1
378A	O-ring	1
379	Teflon O-ring	1
380	Teflon O-ring	1
381	Spring	1
383	Orifice	1
384	O-ring	1
385	O-ring	1
386	O-ring	1
387	Backup Ring	1
388	Backup Ring	1
389	SAE #2 Plug	1
389A	Spool	1
390	O-ring	1
390A	Hex Nut	1
391A	Bumper	1
391C	Maximum Stop Bonnet	1
392A	Spacer	1
392C	Maximum Stop Adjusting Screw	1
393A	O-ring	1
393C	Jam Nut	1
394A	O-ring	1
394C	O-ring	1
395A	Electrical Connector	1
395C	O-ring	1
396A	SAE #10 Plug	1
396C	Backup Ring	1
397A	O-ring	1
398A	O-ring	3

PVG C P-CNN/HNN Control Service Kits

Reference: 520019-200 Ass'y Drwg

Document Number: 520019-SK

Revision: 0 (10-17-07)

Sheet 1 of 2

Description	Kit No.	Design Series	Items Included (quantity is 1 unless noted)	
Pressure Compensator Relief				
Viton Seals	L723987-101	All	307, 308, 312(4), 327, 333	
Nitrile Seals	L723987-102	All		
EPR Seals	L723987-103	All		
Pressure Compensator Adjuster				
Viton Seals	L300574HS04	All	309, 310, 318, 331, 335, 337	
Buna Seals	L300574HS05	All		
EPR Seals	L300574HS06	All		
Maximim Volume Stop				
Viton Seals	L516319-001	All	391C, 392C, 393C, 394C, 395C, 396C	
Nitrile Seals	L516319-003	All		
EPR Seals	L516319-002	All		
Pressure Compensator Spool				
All	L724407-001	F1(A)	305, 328	
Connector Assembly				
115/230 VAC	L315999-220	All	395	
12/24 VDC	315999-228	All		
Solenoid/Selector Valve Kit				
115 VAC	L723789-600		370, 372, 373, 374, 389, 390	
Viton Seals	L723789-604	All		
Nitrile Seals	L723789-605	All		
EPR Seals		All		
230 VAC	L723789-601			
Viton Seals	L723789-606	All		
Nitrile Seals	L723789-607	All		
EPR Seals		All		
12 VDC	L723789-602			
Viton Seals	L723789-608	All		
Nitrile Seals	L723789-609	All		
EPR Seals		All		
24 VDC	L723789-603			
Viton Seals	L723789-610	All		
Nitrile Seals	L723789-611	All		
EPR Seals		All		
Control Seal Kit				
Viton Seals	K520019-001	All		313, 314, 330(4), 331, 332(2), 333, 334(2), 335, 336(2), 337, 338(2), 345, 374A, 378A, 393A, 394A, 397A, 398A(3), 379, 380, 385, 386, 387, 388, 390
Nitrile Seals	K520019-002	All		
EPR Seals	K520019-003	All		
End Cap Assembly				
Viton Seals	L516337-501	F1(A)	303, 304, 305, 306, 307, 308, 309, 310, 312(4), 314, 315(3), 318, 320, 321(2), 322, 325, 327, 328, 330(3), 331, 332, 333, 334(2), 335, 337, 338, 340, 348(2)	
Nitrile Seals	L516337-502	F1(A)		
EPR Seals	L516337-503	F1(A)		

PVG C P-CNN/HNN Control Service Kits

Reference: 520019-200 Ass'y Drwg

Document Number: 520019-SK

Revision: 0 (10-17-07)

Sheet 2 of 2

Description	Kit No.	Design Series	Items Included (quantity is 1 unless noted)
Soft Start Module			
115VAC Coil/Cable Connector			
Viton Seals	L723004-025	All	
Nitrile Seals	L723004-820	All	
EPR Seals	L723004-821	All	
230VAC Coil/Cable Connector			
Viton Seals	L723004-125	All	
Nitrile Seals	L723004-822	All	
EPR Seals	L723004-823	All	370, 371, 372, 373, 374, 375(4), 376, 378, 389, 390, 391, 392, 393, 394, 395, 396, 397, 398(3)
12VDC Coil/Cable Connector			
Viton Seals	L723004-225	All	
Nitrile Seals	L723004-824	All	
EPR Seals	L723004-825	All	
24VDC Coil/Cable Connector			
Viton Seals	L723004-325	All	
Nitrile Seals	L723004-826	All	
EPR Seals	L723004-827	All	
Footnotes for Design Series			
(A) End cap must match control housing, control housing must match pump housing			
E1 series end caps fit E1 series control housings			
A1, B1, C1, C2 end caps fit A1, B1, C1, C2 control housings			
F1 series end caps fit F1 series control housings			
F1 control housings fit F1 pump housings			
A1, B1, C1, C2, E1 control housings fit A1, B1, C1, C2, E1 pump housings			

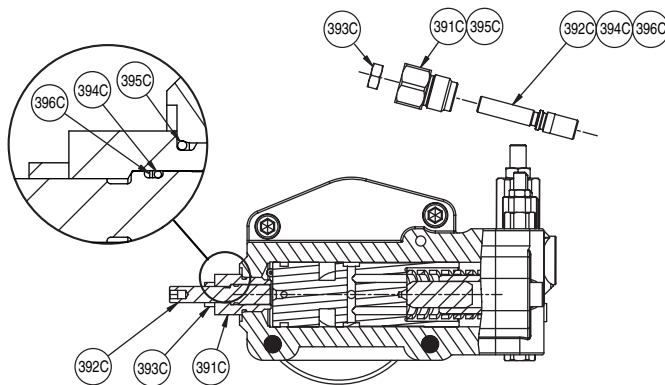

NOTE:
Volume stop is adjustable from full stroke to neutral with fifteen turns (7% per turn). Clockwise reduces stroke.

OILG0415

Figure 8. Exploded Parts Drawing for "P-CNN/H" Maximum Volume Stop, Series F1U Control

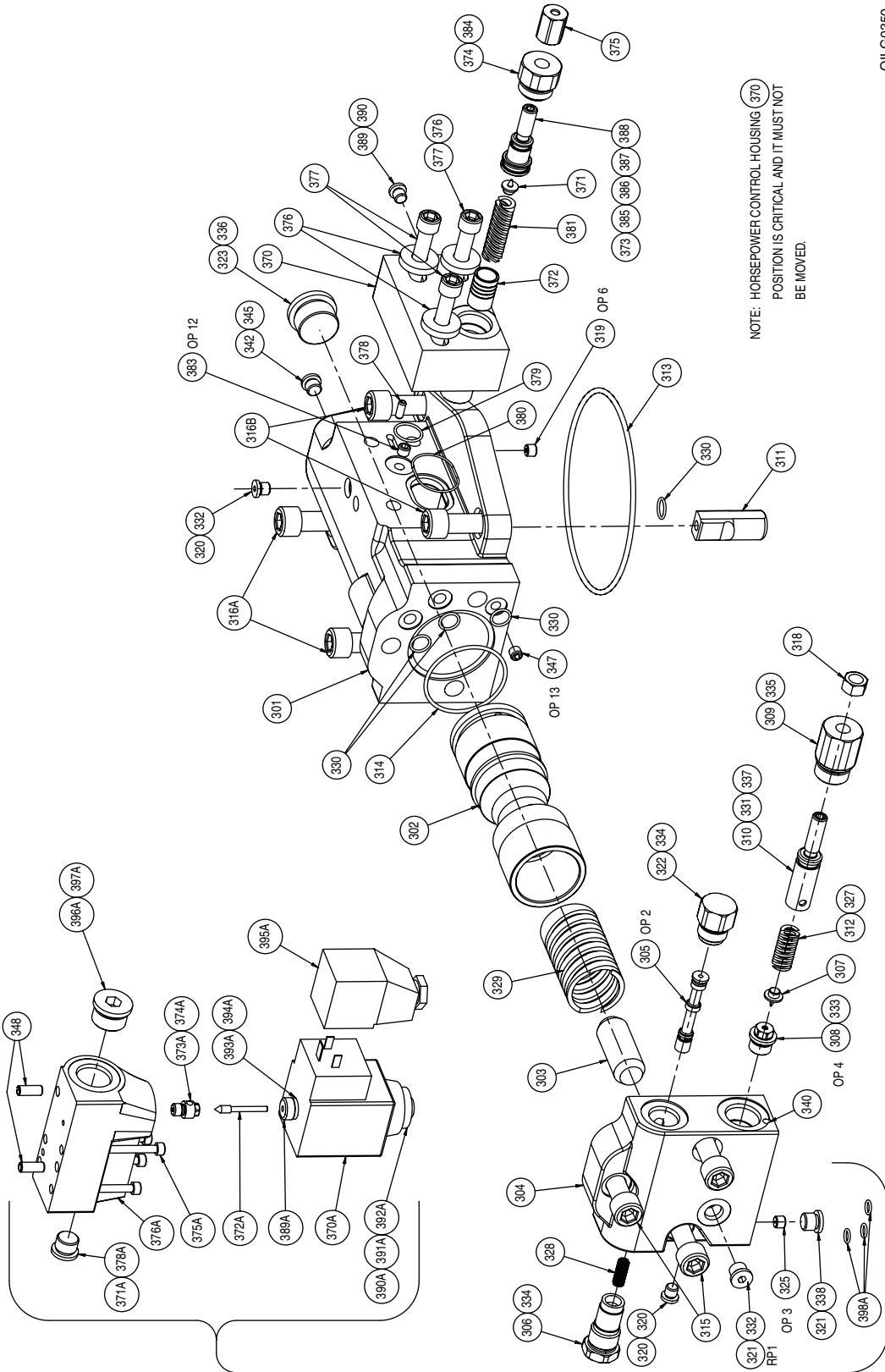

OILG0350

Figure 9. Exploded Parts Drawing for “P-CNN/H” Single Pressure - Soft Start with Horsepower Limiter, Series F1U Control (520019-200 sheet 1)

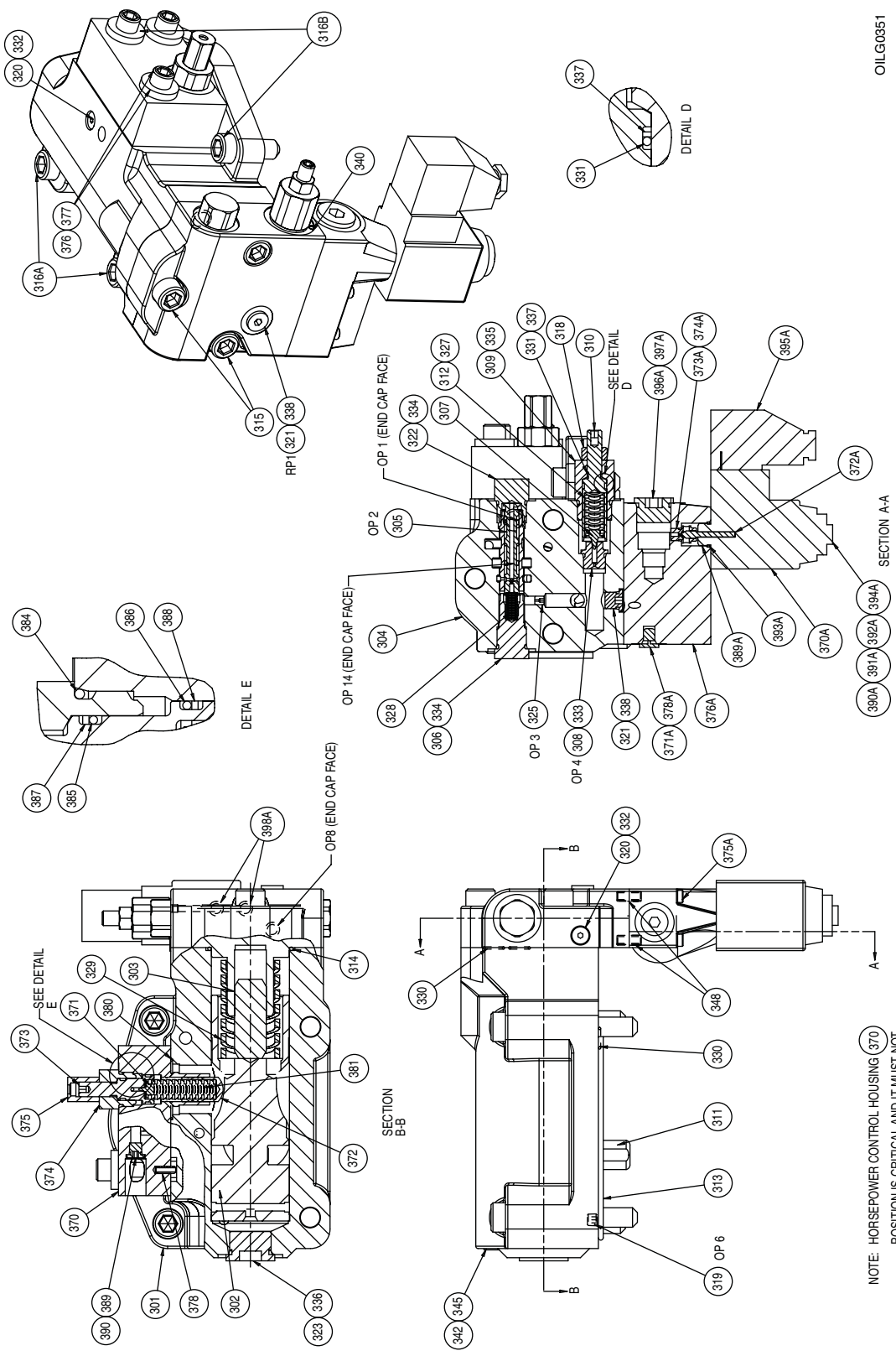

Figure 10. Cross Section Parts Drawing for "P-CNN/H" Single Pressure - Soft Start with Horsepower Limiter, Series F1U Control (520019-200 sheet 2)

AFTER SALES SERVICES

At Oilgear we build products to last. It is the nature of this type of machinery to require proper maintenance regardless of the care we put into manufacturing. Oilgear has several service programs in place to help you.

STAY-ON-STREAM SERVICE

By signing up for Oilgear's Stay-On-Stream program, you can prepare for problems before they happen. Certain field tests such as fluid testing, slip testing and electronic profile recording comparisons can be performed by our field service people or your own factory trained personnel. These tests can indicate problems before they become "down-time" difficulties.

SERVICE SCHOOLS

Oilgear conducts training to train your maintenance personnel. "General" hydraulic or electronic training is conducted at our Milwaukee, Wisconsin plant on a regular basis. "Custom" training, specifically addressing your particular hydraulic and electro-hydraulic equipment, can be conducted at your facilities.

SPARE PARTS AVAILABILITY

Prepare for your future needs by stocking Oilgear original factory parts. Having the correct parts and necessary skills "in-plant" enables you to minimize "down-time." Oilgear has developed parts kits to cover likely future needs. Oilgear Field Service Technicians are also ready to assist you and your maintenance people in troubleshooting and repairing equipment.

