

### Installation Drawing Electronic Proportional Pressure Compensator Control (A Frame)

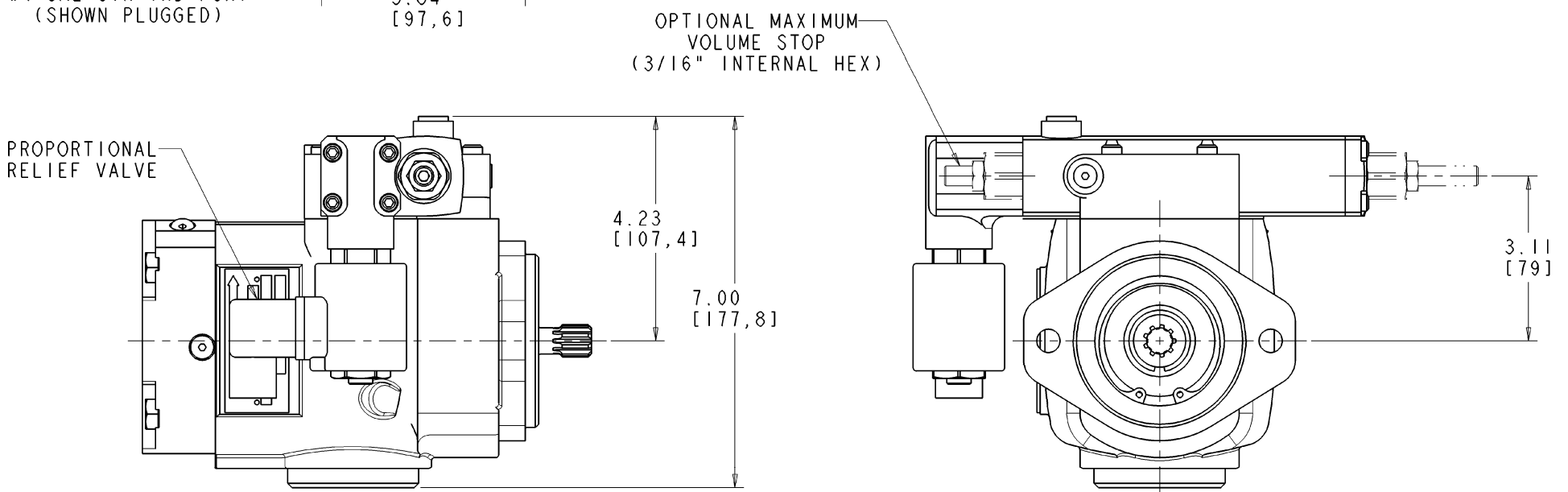
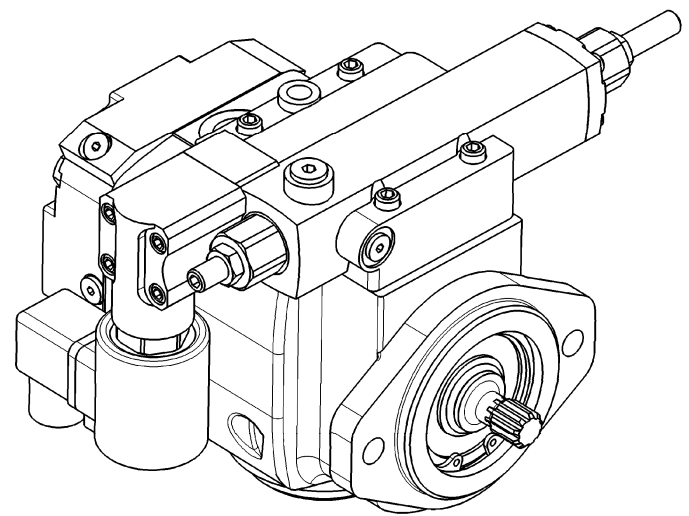
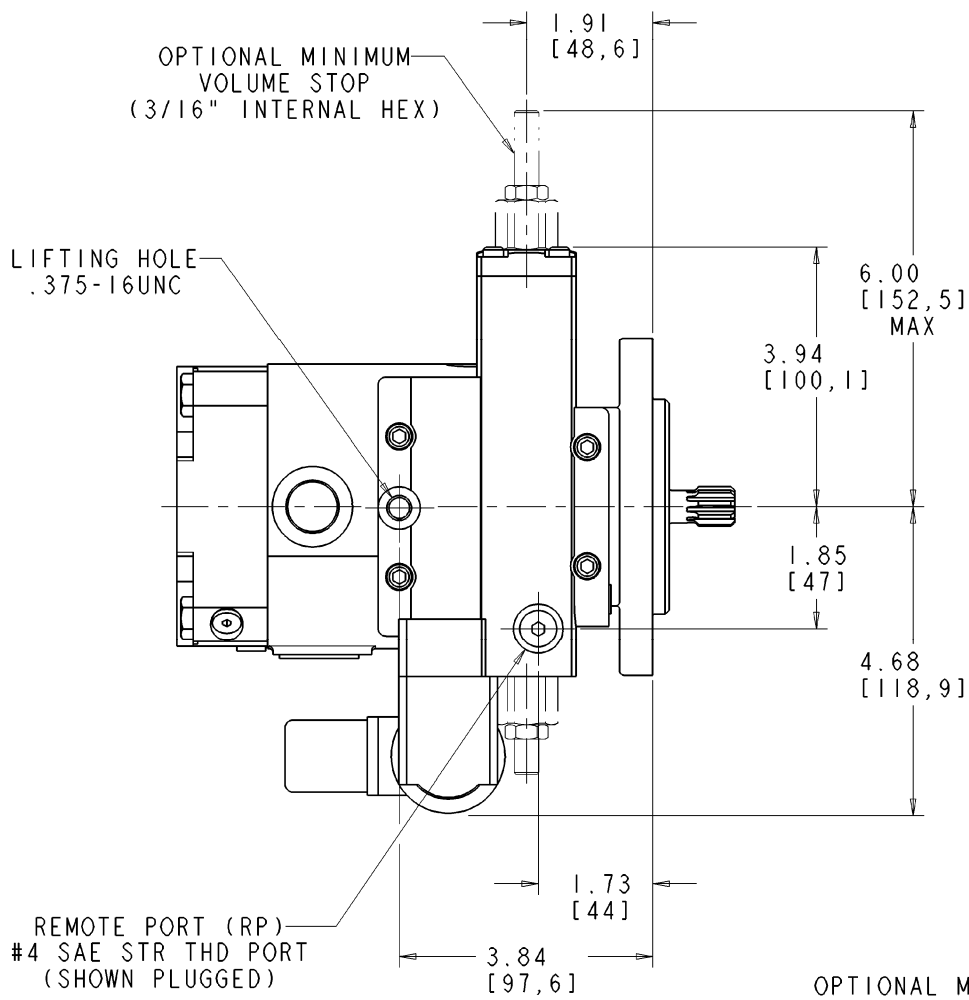
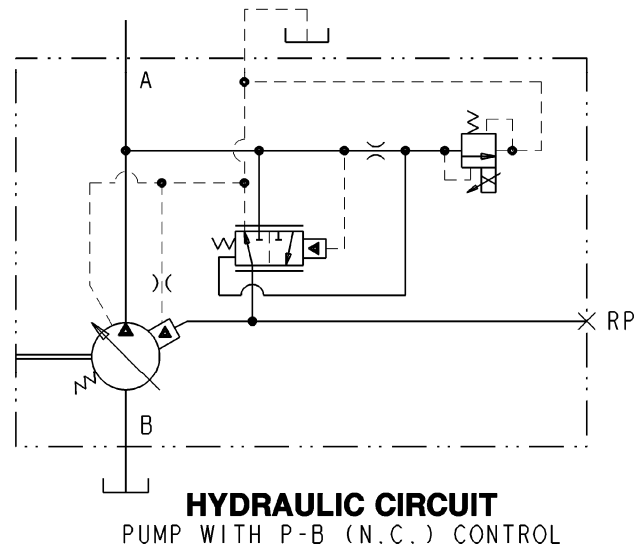
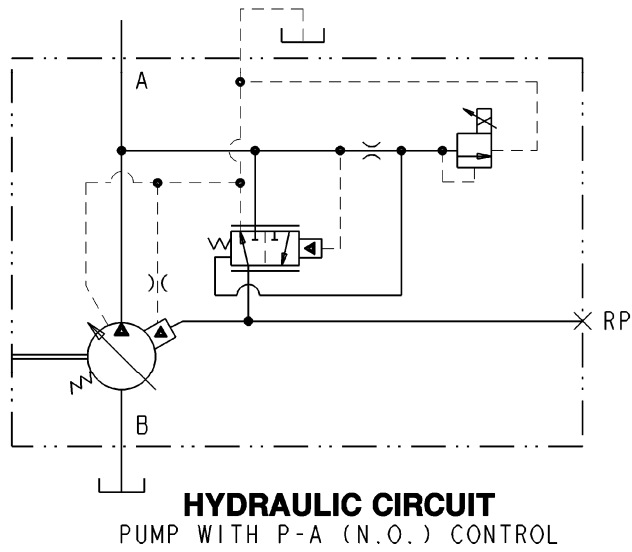

FOR BASIC PUMP DIMENSIONS SEE PLANOGRAPHS:  
DS-47480, DS-47481, DS-47482

520012-107

Telephone: (414) 327-1700  
Fax: (414) 327-0532

**OILGEAR**  
2300 So. 51st Street  
Milwaukee, WI USA 53219

Issued: June, 2009  
**DS-48108**