

10689	APR E	M	W	DR G M
PARTS DRAWING				
SPECIAL "DX" PUMP				

ADJUSTMENT FOR PORT "B"

ADJUSTMENT FOR PORT "A"

* ITEMS 154 B 155 ARE FURNISHED ONLY AS COMPLETE ASSEMBLY

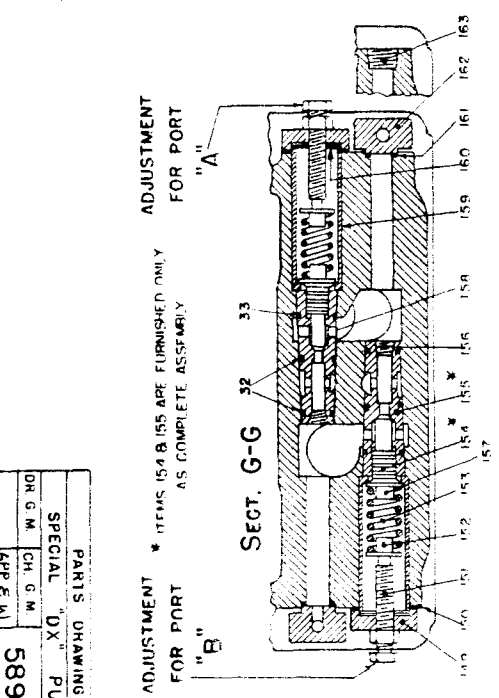
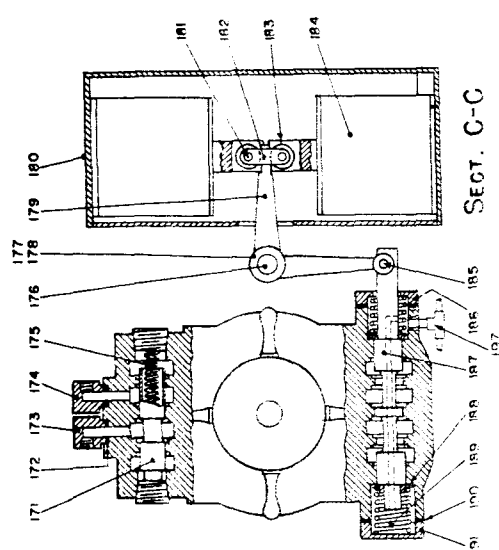
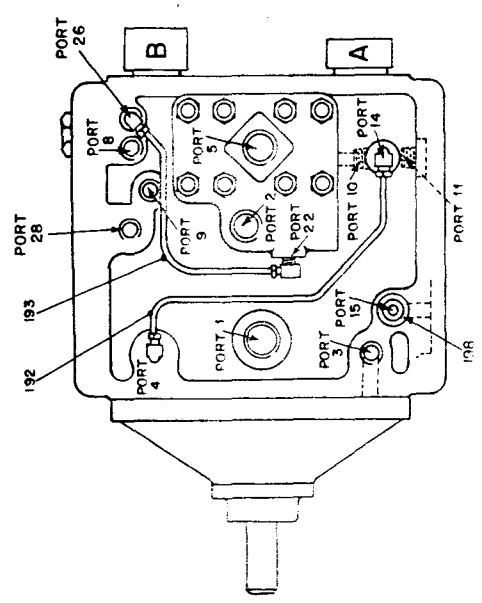

PARTS DRAWING

SPECIAL "DX" PUMP

OIL CIRCUIT DS-947833
COOLER INSTALLATION
DRAWING DS-47905
COOLER OIL CIRCUIT
DS-947905

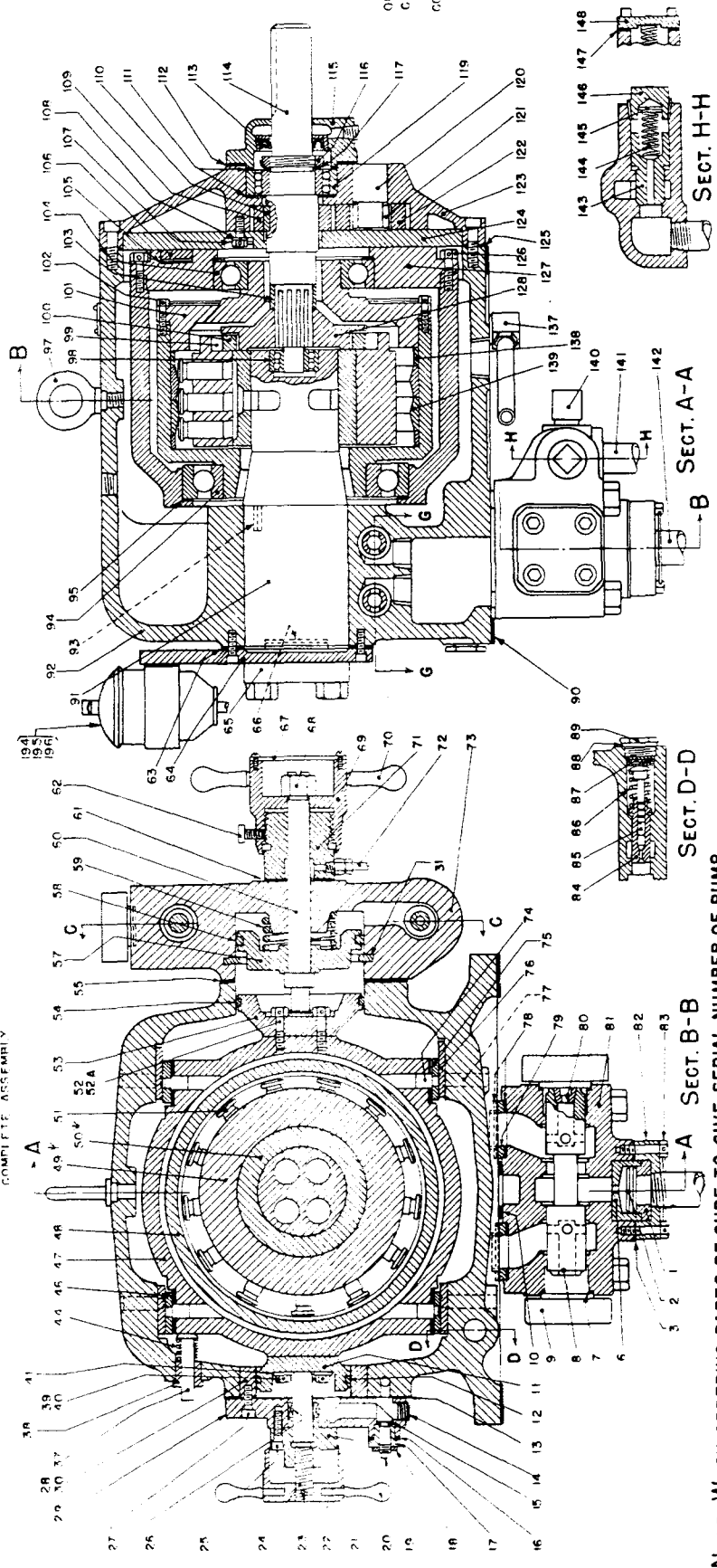

↓ ITEMS 49 & 50 ARE FURNISHED ONLY AS COMPLETE ASSEMBLY

NOTE: WHEN ORDERING PARTS BE SURE TO GIVE SERIAL NUMBER OF PUMP

PARTS LIST
Oilgear Special "DX" Pump

NO.	PARTS	NO.	PARTS	NO.	PARTS
1.	Seat, Check Valve Disc	67.	Cover, Volume Adj. Knob	126.	Screw, Slide Block Cover
2.	Disc, Check Valve	68.	Nut, Volume Adj. Screw	127.	Cover, Slide Block
3.	Gasket, C.V. Cap	69.	Knob, Volume Adj.	128.	Flange, Coupling
6.	Cage, Check Valve	70.	Handle, Volume Adj. Knob	137.	Ell, Ports 4 and 14
7.	Gasket, Suction Valve Flange	71.	Gland, Control	138.	Ring, Spacer
8.	Plunger, Suction Valve	72.	Fitting, Drain	139.	Ring, Thrust
9.	Flange, Suction Valve	73.	Housing, Control	140.	Ell, Ports 22 and 26
10.	Gasket, Suct. Valve Body	74.	Dowel, Slide Block Liner	141.	Pipe, B.P.R.V. Discharge
11.	Piston, Small Control	75.	Liner, Slide Block	142.	Pipe, Suction Check Valve
12.	Ring, Small Cont. Piston	76.	Liner, Pump Case	143.	Plunger, B.P.R.V.
13.	Gasket, Head, Control	77.	Dowel, Case Liner	144.	Spring, B.P.R.V.
14.	Plug, Pipe	78.	Gasket, Suction Valve	145.	Shim, B.P.R.V.
15.	Gasket	79.	Spacer, Suction Valve	146.	Plug, B.P.R.V.
16.	Gasket	80.	Choke, Suction Plunger	147.	Gasket, B.P.R.V.
17.	Cap	81.	Body, Suction Valve	148.	Cap, B.P.R.V.
18.	Nut, Half, Hex	82.	Flange, Check Valve	149.	Cap, H.P.R.V.
19.	Plunger, Orifice	83.	Screw, C.V. Flange	150.	Gasket, H.P.R.V. Cap
20.	Handle, Control	84.	Plunger, G.P.R.V.	151.	Screw, H.P.R.V. Adj.
21.	Gland, Head, Control	85.	Plunger, G.P.R.V. Dashpot	152.	Guide, H.P.R.V. Spring
22.	Knob, Control	86.	Spring, G.P.R.V.	153.	Spring, H.P.R.V.
23.	Pin, Taper	87.	Shim, G.P.R.V.	154.	Plunger, H.P.R.V.*
24.	Screw, Adjusting, Volume	88.	Gasket, G.P.R.V. Cap	155.	Bushing, H.P.R.V.*
25.	Screw, Cap, Sock. Hd.	89.	Cap, G.P.R.V.	156.	Plug, Pipe
26.	Packing	90.	Gasket, Oil Reservoir	157.	Seat, H.P.R.V. Spring
27.	Screw, Cap, Sock. Hd.	91.	Pintle	159.	Bushing, H.P.R.V. Retaine
28.	Gasket, Adapter	92.	Case	160.	Shim, H.P.R.V. Cap
29.	Head, Control	93.	Key, Pintle Locating	161.	Gasket, H.P.R.V. Blind Ca
30.	Adapter, Control	94.	Bearing, Rear Rotor	162.	Cap, H.P.R.V. Blind
31.	Ring, Snap	95.	Shim, Rear Rotor Bearing	163.	Plug, Pipe
32.	Packing, "O" Ring	97.	Eyebolt	171.	Plunger, Bypass Valve
33.	Packing, "O" Ring	98.	Bearing, Rear Shaft	172.	Gasket, Flange
37.	Stem, Indicator	99.	Roller, Coupling	173.	Flange, Pipe
38.	Bushing, Indicator	100.	Ring, Coupling	174.	Flange, Pipe
39.	Screw, Small Cont. Piston	101.	Cover, Rotor	175.	Spring, Bypass V. Plunger
40.	Wire, Locking	102.	Screw, Rotor Cover	176.	Pin, Solenoid Lever
41.	Gasket, Small Cont. Piston	103.	Spacer, Coupling	177.	Collar, Solenoid Lever
44.	Spring, Indicator	104.	Bearing, Front Rotor	178.	Bushing, Solenoid Lever
46.	Shim, Slide Block Liner	105.	Shim, Slide Block	179.	Lever, Solenoid
47.	Slide Block	106.	Ring, Slide Block Spacer	180.	Cover, Solenoid
48.	Rotor	107.	Screw, G.P. Cover	181.	Pin, Solenoid Link
49.	Cylinder *	108.	Gasket, G.P. Cover Screw	182.	Link, Solenoid
50.	Bushing, Cylinder *	109.	Gear, G.P. Driver	183.	Roller, Solenoid
51.	Piston, Pump	110.	Key, G.P. Drive	184.	Solenoid
52.	Screw, Large Cont. Piston	111.	Shim, Front Shaft Bearing	185.	Pin, Pilot Valve Plunger
52A.	Gasket, Large Cont. Piston	112.	Gasket, Shaft Seal Housing	186.	Cap, Pilot Valve
53.	Piston, Large Control	113.	Seal, Drive Shaft Oil	187.	Plunger, Pilot Valve
54.	Ring, Large Cont. Piston	114.	Shaft, Drive	188.	Seat, Pilot Valve Spring
55.	Gasket, Control Head	115.	Housing, Shaft Seal	189.	Spring, Pilot Valve Plung
57.	Piston, Control	116.	Nut, Bearing Lock	190.	Gasket, Pilot Valve Head
58.	Ring, Control Piston	117.	Washer, Bearing Lock	191.	Flange, Pilot Valve
59.	Spring, Control Piston	119.	Bearing, Front Shaft	192.	Tubing, Port 4 to Port 14
60.	Screw, Adjusting	120.	Shaft, G.P. Stub	193.	Tubing, Port 22 to Port 2
61.	Gasket, Control Gland	121.	Bearing, G.P. Roller	194.	Filter, Oil
62.	Screw, Adjusting Lock	122.	Gear, G.P. Driven	195.	Valve, Flow Control
63.	Gasket, Cover	123.	Housing, Gear Pump	196.	Gage, Filter
64.	Cover, Pintle	124.	Cover, G.P.	197.	Fitting, Tee, Ermeto
65.	Flange, Pipe Connection	125.	Gasket, G.P. Housing	198.	Valve, 5 # Relief
66.	Gasket, Pipe Connection				

* Parts 49 and 50 and Parts 154 and 155 are furnished only as complete assemblies.

NOTE: When ordering parts be sure to give serial number of pump.